



Expert Panel Meeting on Advancing Medical Decision Making

Final Report

October 2015

Katherine Treiman, PhD, MPH, Tammeka Swinson Evans, MOP,
and Laura Wagner, MPH

RTI International

DISCLAIMER

All statements, findings and conclusions in this publication are solely those of the authors and do not necessarily represent the views of the Patient-Centered Outcomes Research Institute (PCORI) or its Board of Governors. This publication was developed through a contract to support PCORI's work and is being made available free of charge for the information of the scientific community and general public as part of PCORI's ongoing research programs. Questions or comments may be sent to PCORI at info@pcori.org or by mail to 1828 L Street NW, Suite 900, Washington, DC 20036.

CONTENTS

Section	Page
INTRODUCTION	1
Background.....	1
Introduction and Meeting Goals	1
Session 1: Decisions In and Out of Health	3
Overview of Presentations.....	3
Presentation 1: Normative, Descriptive, and Prescriptive Models of Decision Making (Jonathan Baron)	3
Presentation 2: Fuzzy Trace Theory (FTT): Explaining and Predicting Medical Decision Making Across the Lifespan (Valerie Reyna)	5
Presentation 3: Psychology of Number Processing in Decisions (Ellen Peters).....	6
Discussion.....	8
Evidence Gaps	8
Session 2: New Developments in Psychology and Decision Making	10
Overview of Presentations.....	10
Presentation 1: Current Challenges in the Psychology of Medical Decisions (Brian Zikmund-Fisher)	10
Presentation 2: Health, Risk, and Decisions (Nidhi Agarwal)	12
Discussion	14
Evidence Gaps.....	15
Session 3: Ethics and Decision Making	16
Overview of Presentation	16
Presentation 1: Models of Patient-Physician Decision-Making (Angie Fagerlin)	16
Discussion	18
Evidence Gaps.....	18
Session 4: Choice Architecture and Behavioral Economics	20
Overview of Presentations.....	20
Presentation 1: Choice Architecture: An Overview (Eric Johnson)	20
Presentation 2: Behavioral Economic Approaches for Improving End-of- Life Care (Scott Halpern).....	22

Presentation 3: Choice Architecture (Jennifer Blumenthal-Barby)	23
Discussion	24
Evidence Gaps.....	25
Session 5. Facilitated Discussion: Priority Research Questions as Applied to Health Care Decision-Making	26
Introduction/Charge.....	26
Research Priorities	26
Psychology and Decision Making	26
Choice Architecture	26
Other Research Priorities.....	27
Forums.....	27
Other Disciplines	28
Other Recommendations	28
References	R-1
Appendices	
Appendix A: List of Expert Meeting Attendees	A-1
Appendix B: Horizon Scan	B-1
Appendix C: Meeting Agenda	C-1
Appendix D: Presentation Slides	D-1

INTRODUCTION

Background

To learn about the scope of selected topics in medical decision making, identify evidence gaps, and guide the definition of priority areas for new decision sciences research, the Patient-Centered Outcomes Research Institute (PCORI) held an expert meeting on Advancing Medical Decision Making on June 4, 2015. The meeting convened experts from diverse disciplines, including economics, behavioral economics, business and marketing, psychology and cognitive science, and medical ethics (see **Appendix A**). The meeting extended the work of PCORI staff and the Methodology Committee to develop a framework and priorities for PCORI's work in the decision sciences.

PCORI contracted with RTI International to plan the meeting, including developing a horizon scan as background for the meeting. The *Horizon Scan of Selected Topics in Medical Decision Making* (see **Appendix B**) provides a topical overview of four key areas within the field of decision sciences: behavioral economics, choice architecture, psychology and decision making, and ethics and medical decision making. The 1-day meeting began with an introduction from PCORI leadership and Methodology Committee members, followed by panel presentations and a facilitated discussion to identify priority research areas in medical decision making. The meeting agenda is provided in **Appendix C**.

Introduction and Meeting Goals

William Lawrence, MD, Senior Program Officer in the PCORI Communication and Dissemination Research Division, provided an overview of PCORI, including the legislation that established the institute and PCORI's mandate (see presentation slides in **Appendix D**). Dr. Lawrence described the types of comparative effectiveness research (CER) funded by PCORI and the institute's research priorities in five areas: (1) assessment of prevention, diagnosis, and treatment options; (2) improving healthcare systems; (3) communication and dissemination; (4) addressing disparities; and (5) accelerating patient-centered outcomes research and methodological research.

Dr. Lawrence explained that PCORI seeks to advance understanding of new approaches to improve decision making and is interested in a broad range of decisions, including preference-sensitive and non-preference-sensitive decisions as well as patient, caregiver, and clinician decisions. PCORI convened the meeting to obtain expert input in several areas:

- What are the established and emerging areas in decision science research that can be applied to research on medical decision making and behavior change?
- What are the gaps that new research could help to address; and specifically, that PCORI could potentially address through its research portfolio?

- Are there established but underutilized approaches that would fit within the context of CER? For example, is there efficacy data that is ready for testing in a CER approach?

PCORI Methodology Committee members, Drs. David Flum, Mark Helfand, and David Meltzer, provided additional comments about PCORI's goals and the purpose of the meeting. They discussed the need to identify best practices for decision making in high-risk situations, ways to address clinicians' nonrational decision making, and applications of choice architecture approaches in health care. Dr. Flum emphasized that PCORI's goal is not only to create evidence through CER, but also to ensure that evidence is used in real-world practice by clinicians, patients, and families.

This report summarizes the four panel presentation sessions and a final discussion session:

Session 1: Decisions In and Out of Health. This session presented models of decision-making (normative, descriptive, prescriptive) that apply to health and nonhealth decision making; Fuzzy Trace Theory of decision making; decision making across the lifespan; and numeracy issues related to decision making.

Session 2: New Developments in Psychology and Decision Making. This session addressed current challenges in the field of psychology and medical decision making, including issues related to risk perceptions and emotions in decision making.

Session 3: Ethical Considerations in Decision Making. This session examined ethical issues in medical decision making, including overpromotion of mandatory patient autonomy, the impact of the physician's values, and determining the right amount and type of information to provide to patients.

Session 4: Choice Architecture and Behavioral Economics. This session provided an overview of choice architecture, including the tools of choice architecture, evidence of effectiveness, and ethical considerations associated with choice architecture. In addition, experts discussed the use of behavioral economics approaches in the context of end-of-life care.

Session 5: Facilitated Discussion: Priority Research Questions as Applied to Healthcare Decision Making. The experts discussed key evidence gaps and priority research areas that PCORI can potentially address as well as the experts and the disciplines that would best inform advancing the field.

SESSION 1: DECISIONS IN AND OUT OF HEALTH

Overview of Presentations

Session 1 included three presentations:

- Jonathan Baron, PhD, presented three kinds of models of decision making: normative, descriptive, and prescriptive.
- Valerie Reyna, PhD, presented on Fuzzy Trace Theory (FTT, an integrative theory of medical decision making) and developmental differences in decision making across the lifespan.
- Ellen Peters, PhD, presented on the psychology of number processing in decisions.

Key points from the presentations and discussion are summarized below (see presentation slides in **Appendix D**).

Presentation 1: Normative, Descriptive, and Prescriptive Models of Decision Making (Jonathan Baron)

Dr. Baron provided an overview of three models of judgment and decision making, showing that there is an interplay between the models:

- **Normative models**, which describe a standard (the right choice)
- **Descriptive models**, which tell us why people do not always make the right choice
- **Prescriptive models**, which tell us ways to improve decision making.

Normative Models

In the context of health care, the right answer often depends on the individual patient's values. There are several types of normative models:

- **Coherence and correspondence models:** In the case of probability, two kinds of normative models sometimes compete with each other. Ken Hammond refers to these models as coherence and correspondence models (Dunwoody & College, 2009; Hammond, 2007). A coherence model tests the idea that probabilities agree with each other (e.g., if there is a 50% chance of rain then there should be a 50% chance of no rain). A correspondence model refers to agreement with the real world. Certain tools can be used to assess how well a group of probability judgments correspond with the real world (e.g., predicting a 50% chance of rain corresponds to rain having occurred 50% of the time).
- **Utility theory models:** Other models are based on utility theory, which is the idea that there is a best option that results in the most good. The models differ in the way they aggregate utility across various elements. For example, in multi-attribute utility theory, we analyze situations by attribute. Other approaches analyze situations by time period and aggregate across people, which is referred to as utilitarianism or welfare economics.

Descriptive Models

Descriptive models are founded in cognitive psychology and explain the phenomena of decision making and judgment. Descriptive models fall into the following categories:

- **Process models** are based on the mental processes involved in decision making: diffusion models (accumulator) and two-system (default-interventionist, parallel-competitive)
- **Paramorphic models** describe relations among measures without attempting to characterize the mechanisms that lead to these relations. For example, it is possible to predict judgments from a weighted additive combination of attribute values; however, the ability to predict these judgments does not imply that people are mentally adding weighted values.
- **Heuristics** include the tendency for people to pay attention to what is in front of them and to ignore things that are “off screen.” Other heuristics include attribute substitution, which occurs when two attributes are highly correlated (e.g., length and number), and the myside bias, which is a bias toward maintaining beliefs; that is, people discount evidence against their favored beliefs or search for evidence to support their beliefs. A subcategory of the myside bias is motivated reasoning, in which people look for reasons to support what they would like to be true.
- **Psychophysical models** are relevant for quantitative attributes such as time or money. Psychophysical principles include diminishing sensitivity, or the tendency of people to be most sensitive to changes in an attribute at lower rather than higher magnitudes or closer to the reference point. For example, people are more sensitive to the difference between losing \$100 and losing \$200 than they are to the difference between losing \$10,000 and losing \$10,100.

Prescriptive Models

Prescriptive models “prescribe” how to improve judgments and decisions according to normative standards. Advertisers have used prescriptive models for years to influence consumer decisions. There are several types of prescriptive models:

- **Multi-attribute utility theory:** This approach analyzes trade-offs among attributes.
- **Models for communication:** For example, models to communicate probabilities and risks to people so that they can improve decision making.
- **Education, training, and debiasing:** Teaching people to get rid of their biases that depart from normative models.

Clinical practice guidelines are an example of the prescriptive model. These guidelines are developed at “the lowest common denominator” and are often incomplete. Physicians often deviate from the guidelines and may be overconfident about where the guidelines are incomplete.

Omission and Proportionality Biases

Dr. Baron also discussed research on omission bias, which is the preference for harm caused by omissions over equal or lesser harm caused by action. Studies have repeatedly found

that people perceive harmful acts as worse than harmful omissions. Omission bias is relevant to vaccine resistance and has implications for public policy. Even though people have a higher chance of getting a disease if they do not vaccinate than of getting the disease from the vaccine, they are reluctant to vaccinate. At the policy level, omission bias can influence policy makers' recommendations regarding vaccination programs.

The proportionality bias refers to the tendency to pay attention to ratios when comparison of differences are relevant. Dr. Baron gave the example of a treatment that doubles the probability of bad outcome A (from 1% to 2%), but reduces the probability of bad outcome B by 10% (from 50% to 45%), and the outcomes are equally serious. People will perceive the treatment as bad because they focus on the proportions rather than the differences. Because of this bias, it is generally preferable to present absolute rather than relative risk.

Presentation 2: Fuzzy Trace Theory (FTT): Explaining and Predicting Medical Decision Making Across the Lifespan (Valerie Reyna)

Gist vs. Verbatim Representation

The FTT is a new behavioral theory that explains how individuals make decisions based on gist representation, which refers to the "bottom-line" meaning of information. The gist is an intuitive, subjective meaning of information based on an individual's emotions, experience, values, and background knowledge. Gist representation is differentiated from verbatim representation, which is literal and based on surface detail.

Gist representations are influenced by education, background knowledge, culture, and other factors known to affect cognition. Although people share many of the same common values, prioritization of those values can differ (Broniatowski, Klein, & Reyna, 2015). Gist information is retained longer than verbatim information. So, for example, following a clinic visit the patient will remember the gist rather than the verbatim information provided by the physician

FTT and Standard Dual Processes

Dr. Reyna provided an overview of different approaches to decision making, including behavioral economics and psychological theories. She discussed the limits of behavioral economics approaches to influencing decision making. Use of incentives for physicians (e.g., to reduce hospital readmission rates) can change behavior but it does not necessarily improve decision making. Incentivized behaviors tend to be "brittle"; that is, the behavior is memorized, rote, and does not easily transfer to new situations. FTT differs from standard dual processing models of decision making theories. Traditionally, dual-processes approaches contrasted System 1, variously described as intuitive or emotional, with System 2, analytical or logical thinking. System 1 was assumed to be ontogenetically and phylogenetically less advanced. In contrast, according to FTT, gist-based intuition characterizes advanced thinking, confirmed in many studies of development from childhood

to adulthood and from novice to expert. FTT also differs from many dual-process accounts in being supported by dissociations, crossover interactions, mathematical models, and other strong evidence required to assume multiple processes (e.g., verbatim vs. gist thinking).

Thus, FTT would not categorize the unconscious intuitions of experts with impulsive choices as traditional dual-process theories do. Experts are also not typically analytical in the sense of focusing on verbatim details. Rather than becoming bogged down in analyzing details, as is typical of novices, experts rely on gist-based intuition that is associated with better decisions. Improving medical decision making, then, involves “educating intuition” of patients so that they get the gist or bottom line that medical experts understand (Reyna, Weldon, & McCormick, in press).

Development of Gist-Based Reasoning

Fuzzy gist-based reasoning is based on experience; consequently, people become more and more gist-based in their decision making as they mature and gain experience. Dr. Reyna described her early work examining how physicians deviate from clinical guidelines; based on their experience, they have developed a gist understanding of the right course of action. In fact, clinical decisions were often improved when experienced physicians deviated from the guidelines and subsequent versions of the guidelines aligned with the physicians’ deviations (Reyna & Lloyd, 2006). Gist-based decision making develops over the lifespan. People are more prone to gist-based false memories as they age. They are wrong about what actually occurred, but wrong in a way that preserves the basic meaning.

Theory-Driven Applications

Dr. Reyna discussed several studies examining applications of FTT. One study of arthritis drugs found that patients were not getting the gist information about a complicated drug regimen. The researchers developed a balanced, web-based, decision support tool. Options, values, and probabilistic information were described using theoretically supported formulations. Using the Web-based tool, the proportion of subjects making an informed value-concordant choice increased substantially (Fraenkel et al., 2012). In another study, an FTT approach was added to an existing intervention addressing adolescent risk behaviors. By including gist information about pregnancy risk, the effectiveness of the intervention was increased (Reyna & Mills, 2014). In another study, an FTT approach reduced interest in genetic testing among women at low risk for breast cancer (Wolfe et al., 2015).

Presentation 3: Psychology of Number Processing in Decisions (Ellen Peters)

Numeracy in Health

Dr. Peters addressed the importance of numbers processing in the context of health care and health decision making, including decision making about health care plans, medications,

and treatments. Dr. Peters described how numeracy levels can affect information processing and decision making by influencing the degree to which individuals can obtain, process, and understand information (Ratzan & Parker, 2000).

Numeracy is associated with a wide range of health behaviors and health outcomes; low numeracy is associated with more hospital and emergency room visits, higher risk health behaviors, and poor disease self-management. Numeracy also influences information processing and risk perceptions. Dr. Peters discussed how individuals understand numeric information presented in frequency format (e.g., 1 out of 100) as compared with probabilistic format (e.g., 1%). Overall, frequency has a greater impact than percentages on risk perceptions, such that people perceive 1 out of 100 as a greater risk than 1%. Populations with lower numeracy tend to perceive a greater difference between these two presentations. Individuals with high numeracy tend to draw more affective meaning from numbers; as a result, they better understand the gist of numeric information. Presumably because of this, individuals with high numeracy use numbers more, whereas individuals with lower numeracy rely more on nonnumeric information, such as narratives and moods.

Low Numeracy

Many people do not understand or use numbers effectively, including highly educated people. Common tasks that require some level of numeracy are often not performed correctly (e.g., common medication instructions were not followed correctly by about 40% of the population). Numeracy is lower among women and older, less educated, lower income people (including populations uninsured prior to the Affordable Care Act). An Organisation for Economic Co-operation and Development (2013) study estimated the proportion of Americans who fell into five numeracy performance levels. About 9% of the population is at the lowest level (level 1), which means they have the ability to carry out only simple processes such as counting, sorting, and using whole numbers. Another 20% of the population is at level 2, which means they can carry out basic one-step processes such as simple arithmetic and simple percentages (e.g., 50%). Only 9% of the population is at the highest levels 4/5 that are able to use numbers in complex, abstract, and unfamiliar contexts.

Strategies for Communicating about Numbers

Physicians and other health care providers can improve how they communicate with patients and consumers about numbers by using several evidence-based, communication strategies (Peters et al., 2014). These strategies can be applied broadly, but they are especially helpful for individuals with limited numeracy:

- Provide numeric information to explain a health decision; even for low numerate populations.
- Reduce the cognitive effort required to understand numeric information, such as presenting fewer options or less detailed information, doing the math for the patient,

keeping denominators consistent, presenting absolute risk versus relative risk, and using appropriate visuals.

- Provide evaluative meaning to increase use of numeric information, particularly when numeric information is unfamiliar, such as labeling or using simple categories. This is the approach used by *Consumer Reports* to rate various products.
- Draw attention to salient information; for example, instead of presenting how many calories are in a cookie, present the amount of exercise required to burn off the calories.

Discussion

The discussion during this session revolved around the following key points:

- The connections among normative, descriptive, and prescriptive models; specifically about whether one begins with a normative model and then identifies what people actually do (descriptive model). Then, based on that understanding, determine the prescriptive model.
- The reasons that physicians sometimes depart from clinical guidelines. What biases and distortions are involved? Dr. Baron noted there are many times when the rules are insufficient. The issue is that clinicians may be overconfident about deviating from the guidelines.
- Whether and how to use gist and verbatim information together. Does gist information replace verbatim information, or should both gist and verbatim information be presented?
- Ethical considerations associated with applications of FTT, specifically if the gist is presented to patients in place of verbatim information. There was agreement that patients should be given the verbatim information and have the right to extract their own gist.
- Approaches for increasing health numeracy.
- The circumstances (if any) under which it would be appropriate for physicians to make decisions for patients if patients are not able to understand relevant information.
- Understanding perceptions of risk and the importance of weighing the patient's perspective. For example, although the risk of a catastrophic outcome may be very small, the patient's threshold for this type of risk is understandably low. People's values are not idiosyncratic or irrational in these cases.

Evidence Gaps

The following evidence gaps were identified over the course of this session:

- What are the different ways to be numerate (e.g., objective numeracy, subjective numeracy, approximate sense of numbers) and how are these different types of numeracy associated with health behaviors and health outcomes? What are the best approaches to increasing health-related numeracy?

- What are the differences in thinking, such as verbatim vs. gist processing, that emerge over the lifespan that facilitate or impair medical decision making? Related questions include: Should adolescents make medical decisions? How can gist thinking be tapped among older decision makers?
- What are the unintended consequences of shared decision making? For example, if patients are given too much responsibility for decision making, will that decrease their willingness to accept risky treatments?
- What are the reasons physicians deviate from clinical guidelines? How often does this occur? Do patients benefit when this occurs?

SESSION 2: NEW DEVELOPMENTS IN PSYCHOLOGY AND DECISION MAKING

Overview of Presentations

Session 2 included two presentations:

- Brian Zikmund-Fisher, PhD, addressed current challenges in the field of psychology and medical decision making
- Nidhi Agrawal, PhD, examined risk perceptions and emotions in decision making

Key points from the presentations and discussion are summarized below (see presentation slides in **Appendix C**).

Presentation 1: Current Challenges in the Psychology of Medical Decisions (Brian Zikmund-Fisher)

Dr. Zikmund-Fisher discussed five themes related to psychology and decision making: (1) information evaluability, (2) narrative vs. facts, (3) psychological underpinnings of overuse, (4) mental models of risk, and (5) experiential learning. He noted that he aims to take an applied, translational approach to address issues in medical decision making.

Information Evaluability

The term “information evaluability” comes from the business and marketing field. Christopher Hsee and other researchers have examined product attributes and the ways people evaluate those attributes based on whether they are evaluating the product in isolation or in comparison with other products (Hsee, 1996; Hsee, Loewenstein, Blount, & Bazerman, 1999; Hsee & Zhang, 2010). This research is relevant because, in the context of health care, sometimes people are presented with health data or health care options in isolation. When this happens, people may lack the contextual knowledge to use the information they have.

Dr. Zikmund-Fisher noted that it is not possible to communicate health information neutrally. Depending on how they present information, physicians, health educators, and others influence people in different ways. In building the science of presenting data, we need to consider the context in which data are presented (e.g., whether presented in isolation or compared with other risks) and accept that context can drastically alter the gist meaning patients take away from their data. Patients increasingly have access to their health information; for example, they have access to lab results on patient portals and to data from self-monitoring devices. Patients need to have the appropriate context to understand these types of information. Absent context, a patient may see that their cholesterol value or platelet count is outside of the standard reference range but be unable to tell whether that value represents a small or large risk to her health. A user-centered

design approach is needed to design communications and decision support tools to help patients understand and use information appropriately.

Narratives vs. Facts

There is a natural human tendency for storytelling and narratives. People are “hard wired” for narrative as a way to make sense of the world. However, we have limited understanding of different types of narrative and how narratives influence decision making. Dr. Victoria Shaffer and Dr. Zikmund-Fisher recently proposed a taxonomy of narratives that may be useful for examining the influence of narratives in medical decision making (Shaffer & Zikmund-Fisher, 2013). For example, one dimension of the taxonomy is narrative content, and they define three types of narratives:

- **Process narratives**, which describe the process a person used to make a particular health-related decision (e.g., discovering the need to consider different issues or search for different kinds of information in the process of making a decision).
- **Experience narratives**, which describe experiential aspects of diseases or treatments and provide rich, concrete understanding about what it is like to have a given disease and have a specific procedure or treatment (e.g., what it feels like to manage and adapt to a colostomy, what it feels like to have a mammogram done, or what it feels like to have severe shortness of breath).
- **Outcome narratives**, which describe the psychological or physical health outcomes associated with a particular individual's health-related decision (e.g., whether or not a joint replacement surgery actually provided the hoped for mobility improvements, or whether or not a cardiac procedure actually provided pain relief).

Psychological Underpinnings of Overuse

In certain contexts, especially those related to treatment of active diseases or conditions in ill patients, it is often more difficult to convince someone *not* to do something (e.g., to watch and wait to see whether a cancer grows) than to act (e.g., by having surgery to remove the cancer, which also causes significant side effects) (Fagerlin, Zikmund-Fisher, & Ubel, 2005). The action bias can explain why people overuse tests, procedures, and technology despite evidence of inefficacy or harm. Examples of overuse include failure to discontinue screening (e.g., beyond recommended age) and overtreatment of low-risk cancers. Labeling a condition as a disease as opposed to just a set of symptoms also contributes to action bias (Scherer, Zikmund-Fisher, Fagerlin, & Tarini, 2013). Currently, there are efforts to measure the predisposition to maximize testing and use of active treatments in medical contexts. Developing a better understanding of the psychological underpinnings of the action motivation (and when people may be willing to accept not being tested or having active treatment) has significant potential to optimize utilization of health care resources.

Mental Models of Risk

Mental models refer to lay models of the way the world works, and understanding these models can be essential to developing effective risk communications. In the health care context, people have mental models about why something is or is not risky and why a behavior is appropriate or not appropriate. Patients can have misconceptions because they use an inappropriate metaphor; for example, people often apply a plumbing metaphor to make sense of clogged arteries, which influences their decisions about coronary stenting. In communicating information with patients, it is important for physicians to consider the patient's mental model, identify critical misconceptions, and focus the communication in these areas. This "less is more" approach gives patients the information that will have the most impact on decision making rather than everything that might be seen as relevant.

Experiential Learning

Currently, decision support is very cognitive and more emphasis is needed on learning based on experience (i.e., experiential learning). For example, the role of experience is central to the issue of vaccine resistance. The perceived risk for getting a vaccine-preventable disease is low for many people because most people today have no first-hand experience with polio, pertussis, and other diseases. It is hard to be concerned about something you have never seen. We need to find ways to give people experiential learning, such as through training or games. We may also think about values clarification as a type of experiential learning, because values clarification helps people imagine what would happen with multiple different outcomes, to think concretely about the trade-offs, and then to let that experience guide their decisions.

Presentation 2: Health, Risk, and Decisions (Nidhi Agarwal)

Dr. Agarwal explained that she comes from a marketing background where the practice is to segment populations for marketing purposes. This approach can be used in communication to support medical decision making. Dr. Agarwal's presentation covered five topics:

- (1) determinants of risk perceptions, (2) emotional influence on decision making,
- (3) contextual influences, (4) givers vs. recipients, and (5) health vs. nonhealth reasons.

Determinants of Risk Perceptions

Peoples' risk perceptions are influenced by memory and what is currently on their mind; motivation for addressing a health consideration; and their feelings related to the health consideration. People tend to discount risk associated with less frequent behaviors. Dr. Agarwal gave the example of risk perceptions about hepatitis C. Patients pay less attention to the risk associated with getting a tattoo because (for most people) this is an infrequent behavior than to the risk associated with getting a manicure, which is a more frequent behavior. Risk communication should be tailored to the factors that are most salient to the

patient. Risk communication also needs to address an individual's sense of invulnerability (e.g., "that's not going to happen to me").

Emotional Influences on Decision Making

It is important to understand people's emotional response to risk and identify ways to leverage feelings of hope and anxiety to support decision making. For example, there may be ways to leverage a patient's anxiety to get them to search for more information to support decision making.

Emotions can determine the decision making context. For example, if someone is feeling hopeful they may make suboptimal decisions because they think things are going to work out. Marketing relies on the idea that people will consume more if they are feeling hopeful. In the medical context, hope can empower people to adhere to a treatment. However, hope may also have negative effects. We need a better understanding of when hope has positive vs. negative effects.

Contextual Influences

Dr. Agarwal discussed mindful (intentional) and mindless (habits) behaviors. In the health care setting, patients are encouraged to be intentional about their decisions. In contrast, in marketing consumers are encouraged *not* to think about their purchasing decisions. Dr. Agarwal shared the marketing expression that "thinking rarely ends well." She asked how we can take advantage of mindless behaviors to improve health; for example, by constructing environments such that healthy behaviors are automatic.

As an example of how context affects health behaviors, Dr. Agarwal shared a study she refers to as "the stale popcorn study" (Neal, Wood, Wu, & Kurlander, 2011) in which subjects were just as likely to eat stale popcorn as fresh popcorn when in a movie theater environment. However, outside the movie theater environment, they ate less of the stale popcorn. This study demonstrates how context and habit (i.e., eating popcorn at a movie theater) influence behavior. Interventions should take habits into account, for example, by disrupting the context associated with an unhealthy habit.

Givers vs. Recipients

The concept of "psychological distance" describes the extent to which thinking about something (e.g., a health risk or outcome) is abstract or concrete. We represent events that are psychologically distant and events that are psychologically proximate in different ways. Distal thinking is the big picture, addresses the "why," and is decontextualized. Proximal thinking is more focused on the detail, addresses the "how," and is contextualized. We need to explore how to apply the concepts of distal and proximal thinking to support medical decision making.

The concept of givers and recipients is related to psychological distance and has implications for medical decision making. The physician can be considered as the giver who has a distal perspective and thinks about the big picture in terms of medical decisions. The patient can be considered as the recipient who has a more proximal perspective about the decision.

Health vs. Nonhealth Reasons

People assume that health-related decisions should be very rational. However, people do not always respond to rational arguments; consequently, we need to find other approaches that may be nonrational.

Discussion

Key discussion points during this session were as follows:

- It can be unsettling for clinicians to realize that the way they present information can shape a patient's decision. Dr. Zikmund-Fisher said that we need to provide guidance about how to communicate risk. It is hard, but also very important, to understand what exactly patients need to do and to provide information in different formats or quantities based on the patient's needs at that specific time (Zikmund-Fisher, 2013).
- A communication gap exists between clinicians and patients. Clinicians may overestimate how well they communicate and not adjust their communication appropriately for different patients. To improve communication, it is important to understand both the clinician's and the patient's mental models and find ways to better align them.
- The patient's trust in the clinician can also influence decision making. There are different kinds of trust to consider: trust that the clinician will tell them the right thing to do; trust that the clinician is going to tell the patient how to think about a decision; and trust that the clinician can give patients a window into an experience that they do not have. These types of trust align with the types of patient narratives presented above. It is important to unpack trust in order to understand the clinician-patient relationship and the influence of trust on decision making.
- It is challenging to find the "sweet spot" of providing enough (and the right) information to patients to support decision making, without overwhelming them with information. Dr. Zikmund-Fisher's study on presentation of adjuvant therapy options in breast cancer patients found that presenting options sequentially rather than simultaneously improved comprehension. This approach was especially beneficial for patients with lower numeracy (Zikmund-Fisher, Angott, & Ubel, 2011).
- The current measles outbreak has caused a shift in perceived risks and benefits of vaccines. This speaks to the potential for experiential learning to help people understand the risk of vaccine-preventable diseases. Dr. Zikmund-Fisher said it is possible to show people what an outcome would look like, which enables them to develop a mental model (e.g., of the experience of having a disease). One expert cautioned that experiential learning can have unintended consequences; for example, if teens have sex for a period of time and do not become pregnant, they can "learn" that pregnancy is not a risk.

- Experts discussed the action bias and how to help patients understand that they may not benefit from a test, screening, or treatment. Dr. Zikmund-Fisher suggested that in the example of cancer screening, letting younger patients know that screening is not recommended after a certain age opens the door for discussion of discontinuing screening later.
- Experts noted that temporal discounting (i.e., the tendency to give greater value to rewards as they move away from their temporal horizons and toward the “now”) affects health decisions. They discussed current research on methods to motivate prospection, which refers to the generation and evaluation of mental representations of possible futures.
- There is not a “one size fits all” approach to communicating health information. One expert discussed the difference between targeting information to population groups (e.g., an age group) vs. tailoring for individuals. Sometimes targeting or tailoring makes sense, but in other cases the message is the same for everyone.
- Recent research finds that different personality types are predictors of health behaviors and outcomes. The experts discussed whether personality traits are malleable. There is some evidence that training in childhood can affect personality characteristics.

Evidence Gaps

The following evidence gaps relevant to psychology and medical decision making were identified over the course of this session:

- How can we use emotions to support decision making?
- What types of interventions can promote prospection (i.e., generation and evaluation of mental representations of possible futures)?
- How do narratives, and the different types of narratives, influence risk perceptions and decision making?
- What are the most effective methods for values clarification?
- What approaches can be used to address action bias and overuse in health care? For example, how can clinicians help patients think through the risks and benefits of cancer screening?
- What approaches can be used to foster experiential learning?

SESSION 3: ETHICS AND DECISION MAKING

Overview of Presentation

Session 3 included a presentation by Angie Fagerlin, PhD, on ethics and medical decision making. Key points from the presentation and the discussion are summarized below (see presentation slides in **Appendix D**).

Presentation 1: Models of Patient-Physician Decision-Making (Angie Fagerlin)

Dr. Fagerlin presented four models of patient-physician decision making:

- The *Paternalistic Model*, in which the physician acts as the patient's guardian and makes decisions with limited patient participation.
- The *Informed Decision Making Model*, in which the physician provides the patient with evidence-based, balanced, and understandable information to inform decision making. The patient, who knows her values, preferences, and goals of treatment, combines the medical information she learned from the physician with her knowledge of her values to make a treatment decision.
- The *Professional as Agent Model*, in which the patient provides the physician with her values, preferences, and goals of treatment. The physician, who knows the medical evidence, combines what she learned from the patient with her medical knowledge to make the treatment decision.
- The *Shared Decision Making Model*, which involves mutual information sharing and making decisions based on the medical evidence and the patient's values and preferences.

These models provided the context for Dr. Fagerlin's discussion of ethical considerations in decision making.

Overpromotion of Mandatory Patient Autonomy

In considering the mandatory Shared Decision Making Model, Dr. Fagerlin presented the implications of mandatory autonomy. Although autonomy has been heavily promoted as a foundational component of ethical health care decision making, this approach has potential negative consequences for patients who do not wish to make decisions autonomously (Davies & Elwyn, 2008). The Professional as Agent Model is an alternative approach that physicians can use to mitigate overpromotion of patient autonomy. In this model, physicians draw out their patients' values and goals to help inform the physician's treatment recommendations and decisions.

The Impact of Physicians' Values on Decision Making

A physician's recommendation potentially has a significant impact on the treatment patients receive. In fact, some preliminary evidence suggests that physicians' recommendations

have greater impact on treatment decisions than do patients' own preferences and values (Ubel, 2015).

Physicians may also not realize how their own values may influence their recommendations. Some evidence suggests that physicians may inadvertently convey their own values as facts (Ubel, Comerford, & Johnson, 2015). Consider a case in which a treatment is not recommended by clinical guidelines, but a physician believes the treatment is needed according to his or her own values. If he or she conveys the need for this treatment to the patient as fact, the physician has misrepresented the nature of this recommendation.

The Professional as Agent Model can also help in preventing physicians from overimposing their own values on their patients. By eliciting their patients' values before making treatment recommendations, physicians can more accurately reflect those values in care decisions. Dr. Fagerlin posed the question of how to increase physicians' self-awareness of value-imposing behaviors.

Determining the Right Amount of Information to Provide

The amount of information provided to patients can impact their decision making. Although physicians may tend to assume that patients need and prefer to be given all of the available information, this approach may inadvertently confuse patients and lead to poor decision making. An approach that can better support patient decision making is to focus on two or three main points. With this in mind, Dr. Fagerlin posed several questions: What information should doctors include or exclude? Who has the right to decide what information is or is not critical? How does the amount and type of information given affect patients' decision making and memory?

The Influential Power of Narratives

In medical settings, narratives are often used to communicate insights about processes, experiences, and outcomes in a way that nonnarrative approaches cannot (Shaffer & Zikmund-Fisher, 2013). However, it is the very effectiveness of the narrative approach that has led to controversy regarding the use of patient stories in decision aids. That is, narratives can be quite powerful in influencing patient decisions; consequently, designers of decision aids need to be cautious about how narratives are used. The International Patient Decision Aids Standards (IPDAS) workgroup avoided making a recommendation about the use of narratives for this reason. Nevertheless, there are times when the use of narratives may be warranted to convey information in the most effective way.

Patient Preferences for Communication Approaches

Patient preferences for communication can sometimes be at odds with best practices in communication. This discrepancy poses a dilemma for the designers of patient decision aids when determining how best to convey information that is both engaging and easily

understood. For example, patients prefer three dimensional (3-D) bar graphs to two dimensional (2-D) graphs, despite that 3-D graphs are less readily understood. By favoring patient preferences, decision aids would be more engaging, but we would knowingly run the risk that patients may not accurately understand the information. Is it better to provide accurate materials that we know patients are less likely to read? Similarly with narratives, should patient stories be included in decision aids when they inspire patients to pay attention, even if they may inadvertently bias patients' decision making?

Discussion

Key discussion points during this session were as follows:

- In narratives, risks and benefits are sometimes portrayed as being one-for-one and equal to one another, leading individuals to form inaccurate risk perceptions, a phenomenon known as a false equivalency. One expert asked, given this issue how should decision-aid designers compare risks and benefits in narratives? It was suggested that health communicators be mindful of how risks and benefits, as well as health beliefs, are presented in patient stories.
- Although controversial, narrative approaches remain popular because they present synthesized information or "the gist," rather than an exhaustive list of risks and benefits. They are also effective in presenting underlying reasons for treatment decisions. However, not enough is known about the impact of narratives on patient decision making. One expert noted that most research about the impact of narratives in medical decision making is hypothetical and anecdotal. This being said, there is new research on the use of narratives related to vaccination decisions. More research is needed to investigate the extent to which and how narratives affect patients' decision making.
- One expert pointed out that decision aids are often not evidence-based. For example, values clarification is often recommended as a component of decision aids, despite the fact that it is not definitively known if the process of values clarification actually improves decision making. In fact, there is some evidence that values clarification could be harmful. Future research should investigate what makes a good decision aid, and what features of decision aids are helpful or not helpful.

Evidence Gaps

The following evidence gaps relevant to ethics and medical decision making were identified over the course of this session:

- How can physicians be encouraged and supported to elicit patient goals and values?
- What approaches can be used to increase physicians' self-awareness of when they are "passing values off as facts?"
- How does the amount and type of information given to patients affect their decision making? (For a review on this topic, see Reyna, Nelson, Han, & Pignone (2015)?)
- How should decisions be made about what information to share with patients?

- How do narratives affect patients' decision making in real-world situations, as compared with studies based on hypothetical scenarios?
- What features of narratives can help patients to make the best decisions?

SESSION 4: CHOICE ARCHITECTURE AND BEHAVIORAL ECONOMICS

Overview of Presentations

Session 4 comprised three presentations:

- Eric Johnson, PhD, provided an overview of choice architecture, including choice architecture tools and evidence of effectiveness.
- Scott Halpern, MD, PhD, addressed behavioral economics, with a focus on the use of behavioral economics interventions in the context of end-of-life care.
- Jennifer Blumenthal-Barby, PhD, examined ethical considerations of choice architecture.

Key points from the presentations and discussion are summarized below (see presentation slides in **Appendix C**).

Presentation 1: Choice Architecture: An Overview (Eric Johnson)

Dr. Johnson discussed choice architecture strategies in health, the tools of choice architecture, and evidence of the effectiveness of choice architecture interventions.

Nudges vs. Choice Architecture

Nudges, the structuring of choices in an attempt to encourage people to make better decisions, are often equated with the idea of choice architecture. However, nudges are not the same as choice architecture, and they are just one way to organize the context in which people make decisions. Nor does a purely neutral choice architecture exist. That is, it is impossible to design a system that does not favor one choice over another. These ideas are explored in-depth in *Nudge*, a book that discusses how the government uses nudge theory to change behavior (Thaler & Sunstein, 2008).

Value of Choice Architecture

Choice architecture is not necessarily about changing behavior; rather, as Dr. Johnson noted, it is “anything about how an option set is described and presented.” For example, a system that allows someone to choose health insurance in 3 minutes rather than 20 minutes is a benefit. Good choice architecture helps people form decisions and can make markets more efficient.

Improvement of Choice Architecture

Health care systems can be improved by applying choice architecture principles. One strategy is to change the default option associated with a choice. A default option is defined as a choice frame in which one selection is preselected so that individuals must take active steps to select a different option. A large body of research has shown that people are more

likely to choose the default option. This has been demonstrated in studies of organ donation. Organ donations can be opt-in; that is, the default option is not to be a donor and individuals have to actively select to be a donor. Or organ donations can be opt-out; that is, the default option is to be a donor and individuals must actively select *not* to be a donor. The two approaches result in very different rates of organ donation. With opt-in systems, participation rates are around 42%, whereas with opt-out systems, the participation rates are much higher (Johnson & Goldstein, 2003). Currently, the United States operates on an opt-in architecture, but with a change to an opt-out system, Dr. Johnson suggested that shortages in the donation system would disappear, noting that a change in “one line of HTML code would save a lot of lives.”

Using Choice Architecture to Improve Health Plan Choice

Dr. Johnson presented an example of how health plan choice systems can be improved by using a choice architecture approach. *Health Connector*, a website for choosing health insurance plans, presented users with long lists of options and users had difficulty making cost-effective choices. Dr. Johnson and colleagues conducted an experiment to identify how to encourage patients to make the most cost-effective choice (Johnson, Hassin, Baker, Bajger, & Treuer, 2013). They found that by teaching people common insurance jargon/terms and the formula to figure out cost-effectiveness, people were somewhat better at choosing health plans. Next, they compared a general population of patients to MBA students, who performed even better on the test, demonstrating the effects of higher financial literacy. Then they tested whether monetary incentives led to improved performance, and found no significant differences. Next, they tested the effect of precalculating plan costs on patient choice (essentially “doing the math for them”), which cut mistakes in half. By combining this calculator approach along with a health plan preselection default option, a general population performed better than MBA students. Dr. Johnson explained that the potential cost savings of this choice architecture would be \$456 per person and \$2.47 billion nationwide. He added that, “you may not like choice architecture, but it’s a very expensive thing not to do.”

Useful Tools of Choice Architecture

Drawing on lessons learned from his health plan research, Dr. Johnson summarized approaches that choice architects can use. These include limiting the options by standardizing plans and sorting options by some measure of quality, selecting only the most important attributes to show to patients, doing any necessary math for them, picking “smart” defaults, and designing attributes to be easy to process.

Choice Architecture and Outcomes

Choice architecture can make an enormous difference on outcomes. For example, individuals who wait until age 70 to claim social security benefits get an increased return of

7% per year; consequently, it is in people's best interests to claim their benefits later. The government has tried several methods of encouraging people to retire later. Calculating the "break-even" age (i.e., the age when the amount of money collected from early collection of benefits would be equal to that collected by waiting to start collecting later) actually resulted in individuals retiring earlier by 15 months. A query theory-based approach resulted in individuals retiring 9 months later. Similarly, a checklist approach resulted in an 8.5-month delay. Dr. Johnson suggested that a query theory approach could work well in medical decision-making environments as well. Query theory suggests that choices are sensitive to the way the choice is posed, such as the order in which options and outcomes are presented or attribute labels (e.g., mortality vs. survival rates) (Hardisty, Johnson, & Weber, 2010).

Presentation 2: Behavioral Economic Approaches for Improving End-of-Life Care (Scott Halpern)

Dr. Halpern discussed end-of-life care decisions and the failure of advance directives, as currently implemented. He addressed how behavioral economics insights can help to build better advance directives and improve end-of-life and palliative care.

Importance of Improving End-of-Life Care Choices

Decisions made in the last month of life have important implications for patients and for their surrogates. For example, negative end-of-life experiences have been associated with post-traumatic stress disorder (PTSD) in patients' surrogates (Wendler & Rid, 2011). Advance care planning interventions can help prevent adverse outcomes for patients' surrogates, particularly when the patient has no prespecified choices.

Active Choice

An active choice approach aims to improve advance directive planning. Active choice is based on the idea that "forcing" individuals to choose between two options, instead of letting them go with a default option or avoid choice altogether, encourages more individualized choice. This approach was demonstrated in an unpublished study of prescription drug home delivery (Madrian, 2012). In a recent study by Dr. Halpern's team (Bayard, Josephs, Cooney, Gabler, & Halpern, 2015), a module about advance directives was added to new employee orientation at the University of Pennsylvania. Employees were randomized to a "forced active choice" condition in which they were required to either complete an advance directive or decline to do so, or to the control condition in which they could complete an advance directive or skip ahead to the next section. Giving participants the forced active choice to accept or to decline to complete an advance directive resulted in higher rates of completing advance directives.

Choice Sets

When asked to choose between two choices versus among three or more choices, individuals make different choices. These options are known as choice sets. Relative to how choices are presented, individuals' preferences change (Simonson & Tversky, 1992). This phenomenon seems not to make sense; however, individuals are averse to extremes and sensitive to context. In diabetes patients with end-stage renal disease (2015), a standard set of "yes or no" options was compared to an expanded choice set of options for completing an advance directive (Courtright et al., 2015). Intentions to have an advance directive were higher in the group presented with more options. This approach suggests that there are low-cost and scalable ways to motivate patients to complete advance directives.

Default Options and Patient Preferences

Although default options influence a broad array of decisions, it is uncertain how they influence patients' preferences for end-of-life care, which previously were assumed to be deeply held and individualized. The intention of advance directives is to set limitations on the intensity of care and to limit the burden on the patient's surrogates. Dr. Halpern and colleagues tested individuals' responses to advance directives with different default options: one with an emphasis on comfort and one with an emphasis on extending life. In both conditions, participants were given the option to keep these defaults or to change them. A control group completed advance directives without embedded defaults. The defaults exerted substantial effect on patients' choices. Even after patients were notified of the default intervention, no patients changed their preferences. There were high levels of satisfaction with the plans across all groups (Halpern et al., 2013). This study suggests that individuals may not have strong preferences with regard to end-of-life care. Consequently, intervention designers may have leeway to change default choices on items for which it was previously assumed that no changes could be made. Dr. Halpern noted that longitudinal data are needed on the outcomes of advance directive planning before implementing directives with embedded defaults.

Presentation 3: Choice Architecture (Jennifer Blumenthal-Barby)

Dr. Blumenthal-Barby addressed the applications of choice architecture in health care. She noted several ethical considerations around using choice architecture tools. For more information about the tools of choice architecture, she referred to the MINDSPACE checklist, which lists nine of the most robust influences on behavior (Cabinet Office & Behavioural Insights Team, 2010).

Unanswered Questions

Dr. Blumenthal-Barby raised questions about the use of choice architecture, such as the assumptions that there are no neutral designs and that choice architecture cannot be

avoided. An example is differences between “unavoidable” tools like setting a default and “extras” such as giving information on norms.

Applications of Choice Architecture Tools in Health Care

Dr. Blumenthal-Barby reviewed several existing applications of choice architecture, including defaults, incentives, salience and affect, norms, messengers, priming, and commitments (Blumenthal-Barby & Burroughs, 2012). She posed the following questions:

- What are the ultimate goals toward which we are engaging people in choice architecture? How do we determine the goals ethically, theoretically, and practically? Do we use preferences, an objective list, individual tailoring, or something else? How do we do this at the population level versus an individually tailored level? How do we give patients a voice at the table, rather than letting experts define the ends?
- If the existing environment biases people toward a certain action (e.g., toward surgery for prostate cancer), should we use choice architecture approaches to guide people in another direction (e.g., active surveillance)?
- How do we avoid interfering with autonomy and trust? Is the patient’s autonomy being protected? Are the choice architecture strategies used blocking a patient’s choice? How difficult would it be for the patient to make a choice different than the choice being promoted? Dr. Blumenthal-Barby noted that the more effective an intervention is, the harder it may be for a patient to make a different choice.
- What are patients’ perceptions about the choice architecture intervention? Would patients find it alienating? Would it lead to perceptions that could damage trust?

New Areas for Application of Choice Architecture Tools

Some new contexts exist in which choice architecture insights may be applied, including vaccination, decision aids, end-of-life care, and low-value care. The patient perspective on the goals of choice architecture and how it is applied is also a gap in our current understanding. Dr. Blumenthal-Barby posed the question of how choice architecture can increase uptake of a choice in instances where the best choice is clear, and also in instances where it is not clear. She anticipated that these perspectives will vary based on context and the nuances of each case, such that we cannot merely rely on simple rules of thumb.

Discussion

Key discussion points during this session were as follows:

- What are the best choice architecture interventions and how do they work? Dr. Johnson referred back to query theory and said that the ordering of lists is an essential area for choice architecture.
- When (if ever) is it justifiable to violate patient or parent autonomy for the greater good, with vaccination suggested as one case?
- How much does intent matter when considering the ethics of choice architecture? If a physician unknowingly uses a choice architecture approach (e.g., orders information

in a way that influences the patient's choice), is the physician violating patient-centered decision making and autonomy?

- What effect does disclosure of choice architecture have on patients? Dr. Johnson noted that there is some evidence to suggest that it would have little effect. The point was raised that disclosure may have a paradoxical effect. Specifically, when information about the use of a choice architecture intervention is disclosed, people tend to trust you more. One expert referred to George Loewenstein's work on the unintended consequences of disclosing a choice architecture intervention (Loewenstein, Bryce, Hagmann, & Rajpal, 2014). The experts agreed that disclosure is more of an ethical duty than a practical one.
- The use of defaults and other choice architecture strategies can negatively affect relationships and trust, for example relationships between the patient and physicians or patient and the health care system.
- What is the balance between considerations of individual autonomy and the greater good? By *not* using an effective choice architecture strategy, we may be protecting an individual autonomy yet harming the larger population.

Evidence Gaps

The following evidence gaps relevant to choice architecture were identified over the course of this session:

- What are the most effective choice architecture interventions? Much of the research to date has focused on use of the default option; however, less is known about the effectiveness of other choice architecture tools.
- It is possible to change peoples' choices (e.g., about advance directives) by using defaults and other choice architecture approaches. However, we don't know if defaults help patients make "better" choices. Longitudinal studies are needed to assess patients' quality of life and satisfaction with their advance directive choice and to assess the experience of bereavement of family members and surrogates.
- What are patients' perspectives about choice architecture? What are the consequences of disclosing the choice architecture intervention to patients (e.g., will it damage trust)?

SESSION 5. FACILITATED DISCUSSION: PRIORITY RESEARCH QUESTIONS AS APPLIED TO HEALTH CARE DECISION-MAKING

Introduction/Charge

David Flum, MD, of the PCORI Methodology Committee introduced the final session and explained the charge to experts. PCORI convened the expert meeting to obtain input that can inform PCORI's research agenda in medical decision making. The PCORI funding categories most relevant to research in medical decision making are the portfolios in methodological research and communication and dissemination research. Jean Slutsky, PA, MSPH, who leads PCORI's communication and dissemination research portfolio, explained that much of the early funding was for tool development, such as decision aids. At this point, PCORI wants to focus more on the principles and applications of tools. Dr. Lawrence stressed the importance of effective dissemination of evidence-based interventions.

Dr. Flum asked the experts to address the following questions:

1. What are the key evidence gaps and priority research areas that PCORI can address?
2. What forums exist for discussion of medical decision making? Is there a need for additional meetings? If so, what should be the agenda for those meetings?
3. What other disciplines are needed as contributors to the discussion?
4. What are the barriers to funding outside the traditional academic realm?

Research Priorities

The experts suggested a variety of research areas related to the psychology of decision making, choice architecture, behavioral economics, and other areas.

Psychology and Decision Making

- Examine information processing and decision making across the lifespan.
- Investigate the bioethics and psychology of heuristics and biases, such as omission bias, a cognitive bias in which harmful actions are judged as worse than harmful inactions.
- Study so-called "motivated" reasoning (a strategy to reduce cognitive dissonance, in which individuals continue to hold false beliefs despite evidence to the contrary) both in patients and clinicians.

Choice Architecture

- Investigate the long-term outcomes of choice architecture interventions.
- Investigate patient experiences with choice architecture interventions and the effects of disclosure.
- Implement choice architecture experiments within trials or interventions.

Other Research Priorities

- Study health care decisions that occur outside the health care setting and the influence of family, friends, and other patients on these decisions.
- Conduct research to identify what characteristics of the physician-patient relationship and interactions influence decision making.
- Investigate the unintended consequences of shared decision making.
- Investigate when and why physicians sometimes do not follow clinical guidelines; what are the shortcomings of “cookbook” medicine and how can specialized expertise be broadly accessible?
- Examine how expert judgment can be incorporated into medical decisions. Specifically, how can expert judgments be used in Bayesian analysis where there are some data but the import of the data is unclear? What are the best ways to elicit and aggregate expert judgments to get the best predictions?
- Learn how to help patients think about and report utilities.

Forums

The experts suggested the following conferences as useful for continued discussion of medical decision making:

- Society for Judgment and Decision Making (<http://www.sjdm.org/>)
- Society for Medical Decision Making (<http://smdm.org/>)
- American Society for Bioethics and Humanities (<http://www.asbh.org/>)
- American Marketing Association’s Public Policy & Marketing Conference (<https://www.ama.org/events-training/Conferences/Pages/Marketing-Public-Policy-Conference.aspx>)
- Association for Consumer Research (<http://www.acrwebsite.org/>)
- Behavioral Economics and Health Symposium run by the Leonard Davis Institute’s Center for Health Incentives and Behavioral Economics (CHIBE) at the University of Pennsylvania (currently invitation only)

They also suggested the following approaches to fostering collaboration and advancing the science of medical decision making:

- The DARPA Network “Red Balloon” Challenge model—create a contest that can bring networks together (https://en.wikipedia.org/wiki/DARPA_Network_Challenge)
- Forums with the goal of “matchmaking” for scientists to foster collaboration
- Pre-conference meetings and roundtables

- PCORI consensus group to curate evidence and develop standards
- Forums that bring together experts from various disciplines, as well as applied and basic scientists.

Other Disciplines

The experts recommended that the following types of experts be included in future PCORI efforts to advance medical decision making:

- Clinical psychology
- Experimental psychology (e.g., perception, emotion, memory, reasoning, psycholinguistics, social factors)
- Medical anthropology and sociology
- Researchers with expertise in patient engagement and activation
- Human factors
- User-centered design
- Industry/pharmaceutical stakeholders
- Human-computer interaction researchers
- Process design researchers (research workflow and requirements for a process)
- Implementation scientists
- Marketing science
- Communication science, including researchers with expertise in media effects

Other Recommendations

Experts shared several other recommendations for PCORI activities:

- Curate existing evidence into practical guidance for clinicians and health educators. The International Patient Decision Aids Standards (IPDAS) (<http://ipdas.ohri.ca/>) guidance is a good example of this type of curated evidence.
- Encourage researchers to collaborate across disciplines or between applied and basic scientists; a requirement for this type of collaboration could be included as part of a funding opportunity.
- Encourage rigorous experiments that test medically relevant causal mechanisms of decision making with both patient and nonpatient populations.
- Encourage research to form partnerships with large organizations, such as employers and insurers, in order to conduct relatively fast and inexpensive research using existing outcomes data.
- Encourage researchers to conduct studies within studies to increase the amount of data generated in a single study. For example, researchers could randomize one or

more elements of an intervention during its evaluation trial. PCORI could incentivize this type of study design.

References

- Bayard, D., Josephs, M., Cooney, E., Gabler, N., & Halpern, S. D. (2015). An active choice intervention increases rates of advance direction completion. *In preparation*.
- Blumenthal-Barby, J. S., & Burroughs, H. (2012). Seeking better health care outcomes: the ethics of using the "nudge". *American Journal of Bioethics*, 12(2), 1-10.
doi: 10.1080/15265161.2011.634481
- Broniatowski, D. A., Klein, E. Y., & Reyna, V. F. (2015). Germs are germs, and why not take a risk? Patients' expectations for prescribing antibiotics in an inner-city emergency department. *Medical Decision Making*, 35(1), 60-67.
doi: 10.1177/0272989X14553472
- Cabinet Office, & Behavioural Insights Team. (2010). Applying behavioural insight to health. Retrieved June 22, 2015, from https://www.gov.uk/government/uploads/system/uploads/attachment_data/file/60524/403936_BehaviouralInsight_acc.pdf
- Courtright, K., Madden, V., Gabler, N., Cooney, E., Kim, J., Herbst, N., Whealdon, J., Burgoon, L., Szymula, K., Flash, M., Dember, L., & Halpern, S. D. (2015, October). *Expanded choice sets increase patients' willingness to complete advance directives*. Paper presented at the The Society for Medical Decision Making, St. Louis.
- Davies, M., & Elwyn, G. (2008). Advocating mandatory patient 'autonomy' in healthcare: Adverse reactions and side effects. *Health Care Analysis*, 16(4), 315-328.
doi: 10.1007/s10728-007-0075-3
- Dunwoody, P. T., & College, J. (2009). Introduction to the special issue: Coherence and correspondence in judgment and decision making. *Judgment and Decision Making*, 4(2), 113-115.
- Fraenkel, L., Peters, E., Charpentier, P., Olsen, B., Errante, L., Schoen, R. T., & Reyna, V. (2012). Decision tool to improve the quality of care in rheumatoid arthritis. *Arthritis Care & Research*, 64(7), 977-985. doi: 10.1002/acr.21657
- Halpern, S. D., Loewenstein, G., Volpp, K. G., Cooney, E., Vranas, K., Quill, C. M., McKenzie, M. S., Harhay, M. O., Gabler, N. B., Silva, T., Arnold, R., Angus, D. C., & Bryce, C. (2013). Default options in advance directives influence how patients set goals for end-of-life care. *Health Affairs*, 32(2), 408-417.
doi: 10.1377/hlthaff.2012.0895
- Hammond, K. R. (2007). *Beyond rationality: The search for wisdom in a troubled time*. New York: Oxford University Press.

- Hardisty, D. J., Johnson, E. J., & Weber, E. U. (2010). A dirty word or a dirty world? Attribute framing, political affiliation, and game theory. *Psychological Science*, 21(1), 86-92. doi:10.1177/0956797609355572
- Hsee, C. K. (1996). The evaluability hypothesis: An explanation for preference reversals between joint and separate evaluations of alternatives. *Organizational Behavior and Human Decision Processes*, 67(3), 247–257.
- Hsee, C. K., Loewenstein, G. F., Blount, S., & Bazerman, M. H. (1999). Preference reversals between joint and separate evaluations of options: a review and theoretical analysis. *Psychological Bulletin*, 125(5), 576-590.
- Hsee, C. K., & Zhang, J. (2010). General Evaluability Theory. *Perspectives on Psychological Science*, 5(4), 343-355. doi:10.1177/1745691610374586
- Johnson, E. J., & Goldstein, D. (2003). Medicine - Do defaults save lives? *Science*, 302(5649), 1338-1339.
- Johnson, E. J., Hassin, R., Baker, T., Bajger, A. T., & Treuer, G. (2013). Can consumers make affordable care affordable? The value of choice architecture. *SSRN Electronic Journal*. doi:10.2139/ssrn.2291598
- Loewenstein, G., Bryce, C., Hagmann, D., & Rajpal, S. (2014). Warning: You are about to be nudged. *SSRN Electronic Journal*. doi:10.2139/ssrn.2417383
- Madrian, B. (2012). [Personal communication].
- Neal, D. T., Wood, W., Wu, M., & Kurlander, D. (2011). The pull of the past: When do habits persist despite conflict with motives? *Personality and Social Psychology Bulletin*, 37(11), 1428-1437.
- Organisation for Economic Cooperation and Development (OECD). (2013). *OECD skills Outlook 2013: First results from the Survey of Adult Skills*. Paris: OECD Publishing.
- Peters et al. (2014). Missing.
- Ratzan, S., & Parker, R. (2000). Introduction. In C. Selden, M. Zorn, S. Ratzan & R. Parker (Eds.), *National Library of Medicine current bibliographies in medicine: Health literacy* (Vol. NLM Pub. No. CBM 2000-1). Bethesda, MD: National Institutes of Health, U.S. Department of Health and Human Services.
- Reyna, Nelson, Han, & Pignone. (2015). Missing.
- Reyna, V. F., & Lloyd, F. J. (2006). Physician decision making and cardiac risk: Effects of knowledge, risk perception, risk tolerance, and fuzzy processing. *Journal of Experimental Psychology: Applied*, 12(3), 179-195. doi:10.1037/1076-898X.12.3.179

- Reyna, V. F., & Mills, B. A. (2014). Theoretically motivated interventions for reducing sexual risk taking in adolescence: A randomized controlled experiment applying fuzzy-trace theory. *Journal of Experimental Psychology: General*, *143*(4), 1627-1648. doi:10.1037/a0036717
- Scherer, L. D., Zikmund-Fisher, B. J., Fagerlin, A., & Tarini, B. A. (2013). Influence of "GERD" label on parents' decision to medicate infants. *Pediatrics*, *131*(5), 839-845. doi:10.1542/peds.2012-3070
- Shaffer, V. A., & Zikmund-Fisher, B. J. (2013). All stories are not alike: a purpose-, content-, and valence-based taxonomy of patient narratives in decision aids. *Medical Decision Making*, *33*(1), 4-13. doi:10.1177/0272989X12463266
- Simonson, I., & Tversky, A. (1992). Choice in Context: Tradeoff Contrast and Extremeness Aversion. *J Marketing Res*, *29*, 231-295.
- Thaler, R., & Sunstein, C. (2008). *Nudge: Improving decisions about health, weather, and happiness*. New Haven, CT: Yale University Press.
- Ubel, P. A. (2015). Medical facts versus value judgments--toward preference-sensitive guidelines. *New England Journal of Medicine*, *372*(26), 2475-2477. doi:10.1056/NEJMp1504245
- Ubel, P. A., Comerford, D. A., & Johnson, E. (2015). Healthcare.gov 3.0—behavioral economics and insurance exchanges. *New England Journal of Medicine*, *372*(8), 695-698. doi:10.1056/NEJMp1414771
- Wendler, D., & Rid, A. (2011). Systematic review: The effect on surrogates of making treatment decisions for others. *Annals of Internal Medicine*, *154*(5), 336-346. doi:10.7326/0003-4819-154-5-201103010-00008
- Wolfe, C. R., Reyna, V. F., Widmer, C. L., Cedillos, E. M., Fisher, C. R., Brust-Renck, P. G., & Weil, A. M. (2015). Efficacy of a web-based intelligent tutoring system for communicating genetic risk of breast cancer: A fuzzy-trace theory approach. *Medical Decision Making*, *35*(1), 46-59. doi:10.1177/0272989X14535983
- Zikmund-Fisher, B. J. (2013). The right tool is what they need, not what we have: A taxonomy of appropriate levels of precision in patient risk communication. *Medical Care Research and Review*, *70*(1(suppl)), 27S-49S.
- Zikmund-Fisher, B. J., Angott, A. M., & Ubel, P. A. (2011). The benefits of discussing adjuvant therapies one at a time instead of all at once. *Breast Cancer Research and Treatment*, *129*(1), 79-87. doi:10.1007/s10549-010-1193-4

**Appendix A:
List of Meeting Attendees**

Meeting of the PCORI Expert Panel on Priorities for
Research in Medical Decision-Making
June 4, 2015

Invited Experts on Decision-Making

Nidhi Agarwal, PhD, MBA

Jonathan Baron, PhD

Jennifer Blumenthal-Barby, PhD

Scott Halpern, MD, PhD

Angie Fagerlin, PhD

Eric Johnson, PhD

Ellen Peters, PhD

Valerie Reyna, PhD

Val Simianu, MD

Brian J. Zikmund-Fisher, PhD

PCORI Methodology Committee Members

David Flum, MD, MPH

Mark Helfand, MD, MS, MPH

David O. Meltzer, MD, PhD

PCORI External

Rafael Alfonso Cristancho, MD, PhD, MSc

PCORI Team

Yen-pin Chiang, PhD
Associate Director, Science, Clinical Effectiveness
Research

Jason Gerson, PhD
Associate Director, Science, CER Methods and
Infrastructure

David Hickam, MD, MPH
Program Director, Science, Clinical Effectiveness
Research

William Lawrence, MD, MS
Senior Program Officer, Science, Communication
and Dissemination Research

Katie Lewis, MPH
Senior Program Associate, Science, Addressing
Disparities

Jessica McCreary, MPH
Program Associate, Science, Office of the Chief
Science Officer

Kate McQueston, MPH
Program Associate, Science, CER Methods and
Infrastructure

Katie Rader, BS
Program Associate, Office of the Executive
Director

Jean Slutsky, PA, MSPH
Chief Engagement and Dissemination Officer,
Communication and Dissemination Research
Engagement Executive Team

Hal Sox, MD
Director, Research Portfolio Development, Office
of the Chief Science Officer

RTI International Project Team

Tammeka Swinson Evans, MOP
Health Services Researcher
Health Care Quality and Outcomes Program
Division for Health Services and Social Policy
Research

Katherine Treiman, PhD, MPH
Senior Research Scientist
Patient and Family Engagement Research Program
Center for Communication Science

Laura Wagner, MPH
Research Public Health Analyst
Patient and Family Engagement Research Program
Center for Communication Science

External Attendees

Chethana Acchar
University of Washington, Seattle

Michael Hillmer
Ontario Ministry of Health, University of Toronto

Appendix B: Horizon Scan

June 2015

Horizon Scan of Selected Topics in Medical Decision Making



Prepared for
PCORI Expert Panel on Advancing Medical Decision Making

Prepared by

RTI Authors:

Katherine Treiman
Tammeka Swinson Evans
Laura Wagner
Brittany Zulkiewicz

RTI International
3040 E. Cornwallis Road
Research Triangle Park, NC 27709

RTI Project Number 0214031.0

TABLE OF CONTENTS

Section	Page
Introduction	2
Behavioral Economics	3
Choice Architecture	8
Psychology and Decision Making	13
Ethics and Medical Decision Making	19
References	23

Introduction

The mandate of the Patient Centered Outcomes Research Institute (PCORI) is to improve the quality and relevance of evidence available to help patients, caregivers, clinicians, employers, insurers, and policy makers make informed health decisions. PCORI funds comparative clinical effectiveness research, or CER, as well as supports work that will improve the methods used to conduct such studies.



This horizon scan document has been prepared as background for a meeting of the PCORI Expert Panel on Priorities for Research in Medical Decision Making. The purpose of the Expert Panel meeting is to learn about the scope of selected topics in medical decision making; identify evidence gaps; and guide PCORI in determining priority areas for new decision-sciences research.

This horizon scan provides a topical overview of four key areas within the field of decision sciences:

1. Behavioral economics,
2. Choice architecture,
3. Psychology and medical decision making, and
4. Ethics and medical decision making.

These areas are discussed further in the following sections.

Behavioral Economics

Overview

The field of behavioral economics offers insights that can help us understand how health professionals, patients, and the public make decisions. Based on decades of economic and psychological research, behavioral economics strategies are of increasing interest to governments and large corporations to promote wellness. These insights are being used to enhance interventions that rely on risk perception; medical decisions about competing options; and the presentation of complex choices (see *Choice Architecture* section, below).

"By acknowledging psychological tendencies that underlie decision making, behavior economics offers a descriptively accurate portrait of human behavior and is thus a strong theoretical foundation from which to generate practical techniques for promoting behavior change."

Mitchell and colleagues, 2013

Traditional economic theory assumes that individuals make decisions according to complex mental calculations that consider all available information. However, because traditional models do not account for situational and individual factors, they do not accurately and appropriately explain human decision making.¹

Theories in Behavioral Economics

Prospect Theory

Early work by Nobel Prize winner Daniel Kahneman and colleague Amos Tversky introduced **Prospect Theory**, which asserts that individuals make choices about risky options based on the the gains and losses associated with each possible outcome.

Losses are broadly defined and can include financial costs, time, attention, energy, inconvenience, discomfort, and so on. Losing something causes more mental anguish than gaining something of the same value; this is known as *loss aversion*. Evidence suggests that individuals are more loss averse when comparing gains and losses and that loss aversion tends to occur less when people compare a cost to another similar cost.²

Heuristics

Behavioral economics show that humans' judgments and decisions are guided by simple "rules of thumb" or "mental shortcuts" known as **heuristics**. A heuristic is a strategy "that ignores part of the information, with the goal of making decisions more quickly, frugally, and/or accurately than more complex methods."³

According to Gigerenzer and Gaissmaier,³ heuristic strategies, combined with an individual's core mental capacities, such as the ability to recognize, monitor, and imitate, can be considered a person's "*adaptive toolbox*." Reflection and learning that is based on choices helps individuals develop better decision rules, and these rules become part of



their adaptive toolbox.⁴ Heuristics strategies can be more accurate than more complex strategies, even though they process less information.³

Concepts and Strategies from Behavioral Economics

The table below outlines various concepts of behavioral economics that individuals use to make decisions. These concepts inform strategies that can be used to influence health behaviors.³

Concept	Strategies
<p>Recognition (familiarity, brand awareness)⁴ Individuals tend to prefer options they recognize rather than alternative options. People tend to rely on recognition more for small, frequent, or simple decisions, such as buying personal care products.</p>	<p>Increase familiarity with the healthy option for frequently made health decisions.</p>
<p>Many-Aspect Decision Rules (conjunctive criteria)⁴ Familiarity alone is not enough for complex, costly choices. People tend to use a combination of recognition <i>and</i> other aspects to make large, infrequent, complex decisions (e.g., buying a car).</p>	<p>Conduct research with target audiences to explore the strategies they use to make important choices and what aspects they consider when making a decision.</p>
<p>Discounting (present bias)^{1,5-15} Individuals tend to act in favor of their immediate self-interest at the expense of their long-term well-being. People tend to choose immediate rewards over delayed rewards and to be more deterred by immediate costs than future costs.</p>	<ul style="list-style-type: none"> • Increase the immediate rewards by providing incentives (financial or non-financial). • Identify immediate benefits, such as peace of mind. • Establish commitment plans that offer individuals the chance to commit to a future action (e.g., financial, signed, verbal, public).
<p>Loss Aversion (from Prospect Theory)^{9,12,16} People make choices about risky options based on the gains or losses from potential outcomes. Losses tend to cause more mental anguish than gains of the same value cause mental pleasure.</p>	<p>Reframe costs (e.g., inconvenience, discomfort) as minimal. Loss aversion can help predict people's responses to incentives. Research suggests that people tend to be more loss averse when comparing gains and losses than when comparing similar losses.</p>
<p>Social Norms⁹ People are influenced by what others do. For example, seeing others use a certain product reinforces recognition of that product and sets a social norm.</p>	<p>Convey to target audiences how many of their peers are engaging in the desired health behavior (descriptive norms). Storytelling approaches can have more impact than facts.</p>
<p>Mental Accounting^{1,5} The individual's decision-making process includes how they perceive outcomes and evaluate decisions. The effect of a gain or a loss wears off over time, and the individual "closes the mental account."</p>	<p>Provide incentives separately rather than as part of larger payment (e.g., a \$100 check is more effective than a \$100 decrease in insurance premiums).</p>
<p>Framing Effects¹⁶ When and how options are presented affects people's preferences and choices.</p>	<p>Use message framing effects and personal tailoring to promote healthy behaviors, such as cancer screening. Focus on aspects that are important to an audience.</p>

Applications of Behavioral Economics to Health

Incentives for Physicians

Incentives have been used to reduce the overuse of low-value services, e.g., incentivizing physicians to prescribe lower-cost drugs, reducing insurance payments for unnecessary services, and reimbursing more for life-saving services.¹⁷ There is substantial evidence that physicians are sensitive to the incentives they face; for example, oncologists who are reimbursed based on the chemotherapy drugs they provide administer more of these drugs compared to physicians paid on a capitated basis.¹⁷

Incentives for Patients

Financial incentives designed using concepts from behavioral economics can be effective in promoting health behavior change.¹⁶ Studies find that incentives are effective in the short term and while still in place; however, individuals generally revert to baseline behaviors when the incentive is removed, although some studies have reported medium-term success after programming ends.^{6-9,13,18} For example, a systematic review and meta-analysis of exercise studies found that providing assured or “sure-thing” financial incentives for exercise increased adherence, with some studies showing that the exercise behavior was sustained for longer periods and after the incentives were withdrawn.¹¹ In contrast, interventions using chance or lottery-based incentives did not increase exercise adherence.

A systematic review of smoking cessation incentives also found short-term effects and some limited evidence of medium-term effects. Interventions that used a deposit refund approach had relatively low uptake, but those individuals who did sign up and contribute their own money may achieve higher quit rates than reward-only participants.¹⁸ To date, studies have not found large or consistent relationships between the effectiveness of financial incentives and demographic characteristics (i.e., gender, age, race, income, or education).¹⁰

Influencing Clinicians' Decisions

Health care providers make multiple decisions in the course of a day, often with great speed and in the context of incentives to do more to earn more. Behavioral economics approaches have the potential to influence clinicians' decision making.¹⁶ For example, prices for tests and medications can be framed in ways that are easily understandable. An example would be showing reasonable alternatives for the test, along with quality grades, to help physicians make better decisions. Several studies have demonstrated that providing pricing information on diagnostic tests can reduce the number of tests ordered.¹⁶

The proliferation of computerized physician order entry (CPOE) systems also creates opportunities to influence clinicians to consider the value of diagnostic and treatment alternatives. Patel and Volpp¹⁶ propose several approaches: 1) frame prices in ways that are easily comprehensible and that highlight reasonable alternatives; 2) enhance information on the relative price of interventions by providing relative information on more than just price; 3) use enhanced active choice to make clinicians choose between higher and lower cost alternatives of similar effectiveness when ordering; and (4) in cases where there is a clearly a dominant

alternative from a value standpoint, modify electronic order entry sets such that the higher value options are set as defaults.

Current Areas of Research in Behavioral Economics

The Centers for Medicare and Medicaid Services (CMS) pilot study, Medicaid Incentives for Prevention of Chronic Disease, is testing the use of incentives to influence behaviors related to diabetes prevention, diabetes management, smoking cessation, and other chronic diseases. Ten participating states are investigating the impact of different incentives that vary by type, timing, behavior incentivized, and outcome incentivized.¹⁹

Identification of Research Gaps

A systematic review of cognitive biases and heuristics in medical decision making identifies several limitations of existing research that should be addressed in future research, including the fact that most past studies are based on hypothetical vignettes, which raises questions about applicability to actual decisions. Another limitation is that biases and heuristics have not been studied extensively among health care professionals.²⁰

The following questions outline some research gaps related to behavioral economics:

- What types of interventions are most effective for providing price information to providers in a way that informs prescribing, the ordering of tests, and other decisions?
- What types of behavioral economics interventions can improve provider decision making in the context of decision fatigue and reluctance to try new practices?
- How can behavioral economics strategies be applied in situations where there is not a single “right” choice (i.e., preference sensitive decisions)?
- What is the effectiveness of different types of incentive programs, specifically
 - Under which conditions are financial incentives most likely to drive long-term behavior change?
 - What attributes of incentives (e.g., type, timing) are most effective for different health behaviors and different populations?
 - What is the sustained effectiveness of time-limited incentive interventions?
 - What is the minimum amount needed to incentivize behavior? What features will drive down the minimum threshold?
 - How can behavioral economics interventions align provider and patient incentives to improve decision making?

Key References

- Courtney, M. R., Spivey, C., & Daniel, K. M. (2014). Helping patients make better decisions: how to apply behavioral economics in clinical practice. *Patient Prefer Adherence*, 8, 1503-1512.
- Loewenstein, G., Volpp, K. G., & Asch, D. A. (2012). Incentives in health: Different prescriptions for physicians and patients. *Journal of the American Medical Association*, 307(13), 1375-1376.
- Patel, M. S., & Volpp, K. G. (2012). Leveraging insights from behavioral economics to increase the value of health-care service provision. *Journal of General Internal Medicine*, 27(11), 1544-1547.

Choice Architecture

Overview

Choice architecture is the term for the strategic structuring of decision and choice contexts to account for the predictable and consistent human decision errors known as heuristics and biases (see *Behavioral Economics* section, above). Unlike the rational decisions of all-knowing consumers with unlimited processing capacity modeled in normative economics, human decisions are the result of two competing processes: System 1 and System 2.²¹

“While it is tempting to think that choices be presented in a ‘neutral’ way (‘Just the facts, Ma’am’), the reality is that there is not neutral architecture- any way a choice is presented will influence how the decision maker chooses.”

Johnson et al., 2012

System 1 decision making is quick, intuitive, and emotional, while System 2 decision making is slow and rational. System 2 can override System 1 when a decision necessitates conscious reasoning, but System 1 is largely efficient for everyday decisions and relies on heuristics and biases for intuitive judgments. The advantage of System 1 reasoning is that it is less susceptible to cognitive overload than System 2, allowing an individual to process more information.

Choice architecture interventions, popularized as “nudges” by Thaler & Sustein,²² are promising because they target the intuitive processes of decision making—or System 1.²³ The goal of the “nudge”—also referred to as “libertarian paternalism” or “soft paternalism”—is to use various methods to arrange the physical and social environment in a way that influences people to make better choices.

Principles of Choice Architecture

Basic principles of choice architecture include that when facing choices, people tend to select the default option and use simplifying strategies to assist with their selection, and their selection can be influenced by incentives.

The following table presents six principles of choice architecture.

Principles of Choice Architecture	
Defaults	<ul style="list-style-type: none"> Because people are inclined to do nothing (i.e., not actively make a choice), a large number would be expected to select the default option. There is a default option for every system; the default option will occur if a person does nothing.
Expect Error	<ul style="list-style-type: none"> Human error is expected, and the system is designed to mitigate error.
Give Feedback	<ul style="list-style-type: none"> Performance is improved by giving positive and negative feedback.
Mappings	<ul style="list-style-type: none"> Systems should help consumers understand how different choices will lead to improved outcomes.

Principles of Choice Architecture

Structure Complex Choices	<ul style="list-style-type: none"> When presented with a large number of choices that exceed cognitive capacity for comparison, people use simplifying strategies (e.g., decreasing the number of choices by establishing a cut-off value for certain attributes) to make decisions. Choice architecture is more likely to influence choices when there are a large number of alternatives.
Incentives	<ul style="list-style-type: none"> Choice architecture can utilize incentives to influence behavior and draw people's attention to the incentives.

Source: Thaler, Sunstein, and Balz²⁴

Tools of Choice Architecture

As outlined by Johnson and colleagues, choice architects use tools that fall into two categories: 1) tools used to structure the task choice, and 2) tools used to describe the choice options. Examples for each category are shown in the following tables.

Tools of Choice Architecture

Tools for Structuring the Task Choice

Number of Choice Options	The number of alternatives presented should be enough to require consideration of all options, but not so many as to overload the cognitive capacity of consumers.
Technology and Decision Aids	Interactive decision aids, search engines, product recommendation systems, and personalization can help consumers identify and compare alternatives.
Defaults	Setting a default option influences choice while allowing consumers the freedom to choose.
Choice Over Time	Many choices involve outcomes that evolve over time, which affects choice tasks in three specific ways. (1) people's preference to receive outcomes early leads them to discount future outcomes; (2) uncertainty about the future can cause people's preferences for future outcomes to be unclear, such that certain types of outcomes are systematically over- or under-weighted; and (3) people are often overly optimistic about the future. Tasks can be structured to address intertemporal bias with these types of choices. For example, choice architects can draw attention to future outcomes, or focus the consumer towards "satisficing" (i.e., choose options that meet the basic criteria).
Search Outcomes	The structure of a task influences the strategies a consumer will use to make a decision.

Tools of Choice Architecture	
Tools for Describing the Choice Options	
Partitioning	Consumers will allocate resources evenly when presented with groups of choices or attributes. Partitioning important attributes into several groups, and combining less important attributes into fewer groups, can increase the significance of the more important attributes in a consumer's decision.
Facilitating Comparisons Between Options	<p>Parsimony—Decreasing the number of attributes compared to include only the most important.</p> <p>Linearity—Presenting options in a way such that an increase in one attribute is comparable to the change in another (e.g., miles-per-gallon ratings for cars and energy savings is not linear, but "gallons per 100 miles" is linear to energy savings).</p> <p>Comparability—Using the same scale.</p> <p>Evaluability—Using categories or a familiar scale such as "1–10" to simplify quantitative data.</p>
Attribute Salience	Changing the scale on which the attribute is expressed can increase/decrease importance.
Mapping	Mapping attributes of a choice to different outcomes.

Applications of Choice Architecture to Health

Choice architecture interventions have been studied extensively in the health fields of obesity and organ donation; financial decision making; and energy conservation, such as the following:

- **Changing the environment to influence dietary behaviors and physical activity.** Dietary-related interventions change the environment in which consumers select their food. Food consumption choices can be influenced by strategically organizing menu items²⁶ and by making moderate changes to food accessibility (e.g., moving a dish by 10 inches to make it more difficult to reach, or by changing the type of serving utensil).²⁷ Food consumption at buffets is influenced by the position of the items, with the first items being selected most often.²⁸ Healthy food consumption can be increased by designing buffets to place healthy items in the most selected positions. Several studies examine the use of motivational prompts for exercise (e.g., stair use) and the use of ambience and functional design to promote physical activity.²⁹
- **Default options to influence organ donation and other health-related behaviors.** Utilizing default options to influence health behavior has proven successful in several domains. Organ donation rates are significantly higher in countries with an "opt-out" policy than countries with "opt-in" policies, and greatly increase when a country adopts organ donation as the default option.³⁰ Changing default options also has been shown

to influence pharmacy-related behaviors, such as using generic drugs³¹ and making contributions to flexible spending accounts.³²

Evidence has shown that choice architecture interventions can have durable and long-lasting effects. One type of energy conservation intervention provides households with periodic energy consumption reports that compare their energy use with previous reporting periods and the energy use of their neighbors. Research has shown that treatment effects persist even after the reports are no longer sent to the household and increase with the duration of treatment.³³

Current Areas of Research in Choice Architecture

Current areas of research in the area of choice architecture include the following:

- **Using principles of choice architecture to help consumers select policies in federal health insurance exchanges.** In a series of six studies, Johnson and colleagues³⁴ tested different strategies intended to improve consumer performance, including just-in-time education, smart defaults, and cost calculators. Without interventions, consumers perform at near-chance levels and show significant bias, overweighting out-of-pocket expenses and deductibles. Performance is improved by providing calculation aids and by choosing a “smart default.”³⁴
- **Incorporating tools of choice architecture into decision aids to improve patient decision making.**³⁵ The thinking is that this approach can address common issues associated with decision aids, such as unstable values, order effects, overweighting of rare events, and information overload.
- **Use of choice architecture approaches to promote vaccination among health professionals.**³⁶



Identification of Research Gaps

To date, choice architecture approaches have been studied in a limited number of areas related to health and health care decisions. Extending research into other health areas would be beneficial.

The following questions outline some research gaps related to choice architecture:

- What choice architecture approaches are most effective in influencing decisions related to cancer and other health screenings? What intervention characteristics are most important in influencing screening behaviors?
- How can choice architecture principles be applied in situations where there is not a single “right” choice (i.e., preference-sensitive decisions)?
- What are effective choice architecture approaches to influence health care provider decision making?

- What are effective approaches to incorporate the patient perspective in choice architecture?

Key References

Hollands et al. (2013). *Altering choice architecture to change population health behavior: A large scale conceptual and empirical scoping review of interventions within micro-environments*. Cambridge, MA: University of Cambridge

Johnson, E. J., Shu, S. B., Dellaert, B. G., Fox, C., Goldstein, D. G., Häubl, G., & Schkade, D. (2012). Beyond nudges: Tools of a choice architecture. *Marketing Letters*, 23(2), 487-504.

Thaler, R. H., Sunstein, C. R., & Balz, J. P. (2014). Choice architecture. In: Shafir E, ed. *The behavioral foundations of public policy*. Princeton, NJ: Princeton University Press; 2014:428-439

Marteau, T. M., Hollands, G. J., & Fletcher, P. C. (2012). Changing human behavior to prevent disease: The importance of targeting automatic processes. *Science*, 337(6101), 1492-1495. doi: 10.1126/science.1226918

Psychology and Decision Making

Overview

Decision science is increasingly focusing on psychological theories of information processing and attention to basic perceptual, attentional, memory, and aggregation processes.³⁷ Oppenheimer and Kelso³⁷ consider this a paradigm shift in the field of decision making, which has long been dominated by an economic perspective.



Cognitive Factors in Decision Making

Key cognitive factors in judgment and decision making include the following.³⁸

- **Attention**—Attention is a finite resource that is selectively allocated to salient stimuli. Attention can be consciously oriented by endogenous influences, such as goals and affect, or unconsciously oriented by exogenous influences, such as by changing stimuli.
- **Encoding and Evaluation**—Information is encoded and processed in a context- and goal-specific manner. In decisions made using descriptive information of available options, the evaluation of options are made according to one or more reference points. The value of an option is not absolute. Similarly, probabilities of outcomes are assessed according to their relative rank, not the absolute magnitude of the probability.
- **Memory Processes**—Memory is dynamic and can be changed during the retrieval process. Priming, in which the presentation of a stimulus increases the accessibility of related concepts, can influence consumer choice and information searches. Memory and recognition of situations and options influences inferences used in decisions.
- **Multiple Information Processes**—Emotions related to expected outcomes and the incidental emotions experienced outside of the decision task influence the perceived value of options and the risk-taking of the decision maker.
- **Learning**—Correct feedback is important for improving decision-making importance.
- **Characteristics of the Decision Maker**—Individual and cultural differences in decision making are the result of differences in values, goals, or biological determinants that shift attention to different features of a task, and differences in utilization of automatic and controlled processes due to education, experience, or cognitive ability.

Information Processing Theories

Information processing theories build on evidence from cognitive psychology to account for the influence of factors such as attention, memory retrieval, and memory decay on the integration of information about values and the attributes of available options.³⁷

The following table presents some examples of information processing theories

Information Processing Theories	
Query Theory³⁹	Decisions are broken down into a series of queries. Results of earlier queries are weighted more in the decision process because the processing of those queries interferes with subsequent queries. The order of the queries is influenced by implicit goals.
Decision Field Theory⁴⁰	Decisions are made by accumulating evidence for and against available options and retrieving information about anticipated consequences. A decision is made once evidence for an option reaches a certain threshold. The amount of time spent deliberating is correlated with the threshold for a decision. Under pressure, the threshold for choosing an option is low, but given no or little time pressure, the threshold is higher.
Leaky, Competing Accumulator Model⁴¹	Evidence for and against available options accumulates during the deliberation process, but the weight of the evidence in the decision-making process degrades over time.
Decision by Sampling⁴²	Individuals do not assess the absolute utility or value of a given option, but make ordinal comparisons between options. The value of an option is context-specific.
Voting Agent Model of Preferences⁴³	Decisions are the aggregation of different neural systems, with preferences for specific attributes (i.e., minimizing risk).
Constraint Satisfaction^{44,45}	How individuals value the attributes and features of an option are not stable, and option values cannot be modeled as the weighted sum of attributes and features. The value of the attributes and features of a choice are dependent on the relationship to the attributes and features of other choices.

Dual-Process Models of Decision Making

The distinction between two kinds of thinking has been proposed in many fields and is the focus of much interest in contemporary psychological research.⁴⁶ Although multiple dual-process models of decision making have been proposed, the dual processes are consistently described as intuitive, automatic, and emotional (i.e., System 1) and conscious, deliberative, and rational (i.e., System 2).^{21,47,48}

Dolan and colleagues⁴⁹ developed the mnemonic MINDSPACE to describe the major factors that influence System 1, as shown in the following table.

Major Influences on Automatic Behavior	
MINDSPACE cue	Behavior
Messenger	We are heavily influenced by who communicates information to us.
Incentives	Our responses to incentives are shaped by predictable mental shortcuts, such as strongly avoiding losses.
Norms	We are strongly influenced by what others do.
Defaults	We “go with the flow” of pre-set options.
Salience	Our attention is drawn to what is novel and seems relevant to us.
Priming	Our acts are often influenced by subconscious cues.
Affect	Our emotional associations can powerfully shape our actions.
Commitments	We seek to be consistent with our public promises and reciprocate acts.
Ego	We act in ways that make us feel better about ourselves.

Source: Dolan⁴⁹ (used with permission)

Reyna’s⁵⁰ fuzzy-trace theory (FTT) builds on the dual-process model of decision making to explain how patients use information to make medical decisions. Instead of using verbatim information when making judgments and decisions, people rely on the gist of that information. The gist is an intuitive, subjective meaning of information based on an individual’s emotions, experience, values, knowledge, and other factors; see an example in the text box below.

Fuzzy Trace Theory: Reliance on the Gist

A woman who has been told she has a 22% chance of getting breast cancer may take from that quantitative and objective information a variety of meanings. If her sister has had breast cancer in the past, she may think “I’m going to get breast cancer like my sister.” If she thinks, “My risk of getting breast cancer is higher than average,” she is using previous knowledge to compare her own risk. Reyna argues that understanding the gist of information is more important than being able to recall information verbatim, and that this has implications for current informed consent processes.

Reyna, 2008

FTT also accounts for the role of emotion in decision making. In FTT, emotional associations influence the interpretation of objective information to subjective meaning. According to the dual-process model, System 2 requires that individuals consider the magnitude of risks and benefits with their respective probabilities to determine expected utility. It is well known, however, that emotions affect the processing of such information, causing individuals to ignore the improbability of an adverse occurrence.⁵¹ Positive emotions can also lead to overconfidence and the underestimation of risks. FTT is one proposed mechanism for the effects of emotion on decision making.

Applications of Dual-Processing Theories in Health

Implications for Clinicians' Decision Making

Pat Croskerry, Division of Medical Education at Dalhousie University in Nova Scotia, defined a process for diagnostic decision making by clinicians in which System 1 and System 2 interact.⁵² The model below illustrates Croskerry's process, including the steps of recognition, executive override, dysrationalia override, and calibration to achieve a diagnosis.

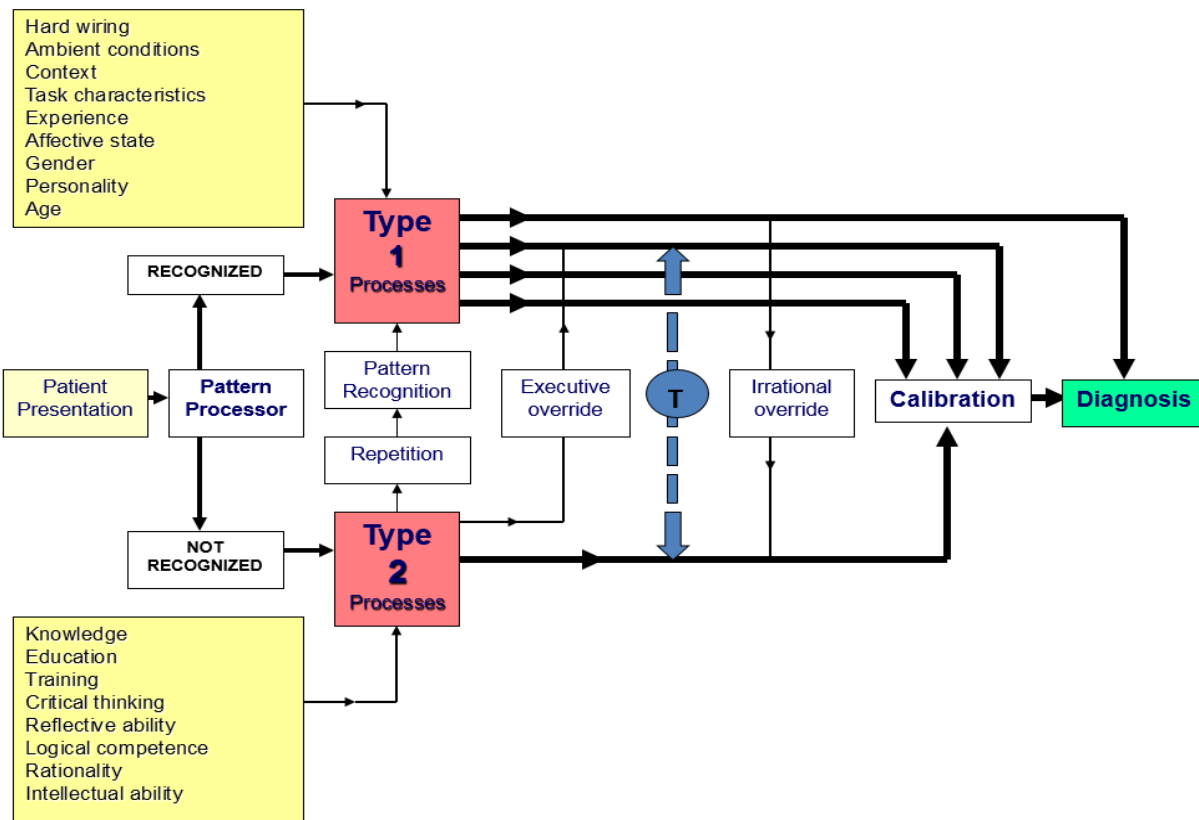

As shown in the model, after exposure to a repeated pattern, the pattern is recognized, and clinicians rely on System 1 to diagnose. System 2 can override System 1 when analysis is required or flaws in System 1 are recognized through reflection. System 1, however, can also override System 2, a process known as dysrationalia override, which leads to an irrational

decision despite knowing the best option. If the intuitive diagnosis is wrong, and the patient does not improve or deteriorates, the clinician will move to System 2 to adjust the diagnosis. A mathematical model of dual-process medical decision making that accounts for the interaction between System 1 and System 2 explains the tendency for overtreatment in current practice.⁵³

"Recognizing dual-process of decision making and reliance on intuitive systems that can lead to errors and biases can improve health care quality, patient safety, and reduce errors."

Croskerry & Nimmo, 2011

Evidence for the effectiveness of interventions based on dual-process theory is limited. Using gist-based decision aids grounded in FTT for colorectal cancer screening may increase patient engagement, but no effect was found on the decision to receive screening.⁵⁴ However, an intervention redesigned to incorporate FTT reduced sexual risk taking in adolescents compared to the unmodified intervention.⁵⁵

Similar results have been found for clinician decision making. Training clinicians to rely on System 2 and recognizing biases when using System 1 had no effect on diagnostic error rates.⁵⁶ Clinician prescribing behaviors, weight advice, and foot examination in the management of Type 2 diabetes is supported by the dual-process model.⁵⁷

Current Areas of Research in Psychology and Decision Making

Current research in psychology and decision making is focused on deepening our understanding of the role of cognitive processes in decision making and the application of these insights to behavior-change interventions. Current research topics include the following:

- Applying decision theories to patient decision-support interventions⁵⁸
- Understanding differences in decision making performance between individuals and groups, and across the life-span³⁸
- The neurological basis of and evidence for a dual-process system of decision making
- Decision making and cognition in health, disease, and aging
- Cognitive moderators of value, preferences, and risk perceptions
- Applying fuzzy-trace theory to modify adolescents' risky decision making.



Identification of Research Gaps

Research is needed regarding how to assess the utilities of patients for different outcomes. Various methods for assessing utilities (or health quality) have been found to be internally inconsistent, inconsistent with each other, affected by variables that should not affect them, or implausible in the results they yield. Research is also needed to improve standard measurement

methods. For example, conjoint analysis is often used to measure relative utilities, and although it suffers less from the major problems just noted, it still suffers from the excessive weight given to the attribute that subjects consider "most important." Another (more radical) approach would be to let expert advisors assign numbers to outcomes on the basis of other information elicited from patients, or to simply suggest choices.

Key References

Johnson, E. J., & Weber, E. U. (2009). Mindful judgment and decision making. *Annual Review of Psychology*, 60, 53.

Kahan, D. M. (2008). Two conceptions of emotion in risk regulation. *University of Pennsylvania Law Review*, 741-766.

Kahneman, D. (2011). *Thinking, fast and slow*. Macmillan.

Oppenheimer, D. M., & Kelso, E. (2015). Information processing as a paradigm for decision making. *Annual Review of Psychology*, 66, 277-294. doi: 10.1146/annurev-psych-010814-015148

Ethics and Medical Decision Making

Overview

The focus of ethics and medical decision making is on the system of moral principles that apply values and judgments to the practice of medicine and decision making. A common framework in medical ethics is the “four principles” approach, which specifies four moral principles that are considered together and weighed against each other.⁵⁹ Additional principles considered in medical ethics include respect for the individual and truthfulness. Conflicts among these principles frequently arise, resulting in ethical conflicts and challenges in medical decision making.

Patient Autonomy, Paternalism, and “The Nudge”

The current literature in medical ethics explores the ideal of patient autonomy and the ethical considerations of paternalism and “nudging” patients towards healthy behaviors.^{22,60,61} Blumenthal-Barby and Burroughs⁶² identify ethically relevant dimensions that should be considered for the utilization of principles from behavioral economics and psychology used to “nudge” people (e.g., the public, patients, health professionals) towards particular decisions or behaviors related to health. For example, the use of defaults raises several ethically relevant considerations: it must be fairly easy for people to opt out of the default option to preserve and respect freedom of choice; it is important that what we default people toward will benefit them more than harm them; and it is important to be aware of and ameliorate potential negative effects of the default on vulnerable populations. Other ethical questions raised about “the nudge” include the ethics of influencing automatic behaviors; the lack of agreement about what is in the patient’s best interest; whether the approach may create obstacles to making other decisions; and whether influence attempts may hurt the patient’s welfare.⁶⁰

Principles of Medical Ethics:

1. Respect for autonomy—rights of the individual to self-determination
2. Beneficence—actions that serve the best interests of the patient
3. Non-maleficence—“first, do no harm”
4. Justice—fairness and equality, such as regarding distribution of health care resources

Gillon, 1994

Typology of Influence and Ethical Considerations

Blumenthal-Barby and colleagues⁶³ examine ethical issues related to different methods of influencing patients, with a focus on psychiatric patients. They define seven types of influence and ethical guidelines related to each, as shown in the Typology of Methods chart on the following page.

Typology of Methods of Influencing Patients' Decision Making		
Types of Influence	Clinical Examples	Ethical Guideline Summary
Direct recommendation	Recommend to a sexually active female patient with bipolar disorder who uses contraception that she discontinue Depakote because of potential harms to the fetus in the event of a pregnancy.	Consider ability of the patient to make autonomous choice, level of confidence in effectiveness of treatment, and magnitude of benefit relative to harm.
Appeal to patient's values and goals	Call depressed patient's attention to the positive effect that treatment could have on her ability to parent her child.	The less that one knows about the patient's values and goals, the less that influence is justified.
Appeal to norms	"Most patients in your situation choose..." "Your deceased wife would have wanted you to ..."	Consider ability of the patient to make autonomous choice, level of confidence in effectiveness of treatment, and magnitude of benefit relative to harm. Norms invoked must be true and must not propagate unjust practices or stigmas.
Intentional framing of information or options	For a patient obsessively concerned with appearance, frame risk of tardive dyskinesia as percentage instead of frequency (knowing frequency bias) or as risk measured against greater, more immediate benefits (knowing primacy and recency biases).	Consider ability of the patient to make autonomous choice, level of confidence in effectiveness of treatment, and magnitude of benefit relative to harm.
Offering concrete incentives	Taking medications, participating in groups, or practicing good hygiene will result in outdoor, phone, or snack privileges, in the provision of housing or disability checks, or in the avoidance of jail.	Consider ability of the patient to make autonomous choice, level of confidence in effectiveness of treatment, and magnitude of benefit relative to harm. In addition, items or privileges to which patients are entitled should not be used as incentives.
Leveling concrete threats	Not following treatment recommendations will result in removal of outdoor privileges, longer hospital stays, or reports of dangerous behavior to employer.	Threats should be considered as methods of influence only as a last resort; after other influence attempts have failed; or if methods are reliably expected to prevent imminent, highly probable, serious, far-reaching, irreversible clinical harms; <i>or</i> if they are the only means of protecting a patient's future autonomy from significant or irreversible impairment
Deception (e.g., concealing, misleading, or lying)	Omitting the option of going home to a patient who has been living in self-neglect; telling a patient who is merely seeking shelter that no beds are available even though there are; or telling a psychotic patient that the medicine will remove a spirit.	Deception should be considered as methods of influence only as a last resort; after other influence attempts have failed; or if these methods are reliably expected to prevent imminent, serious, far-reaching, irreversible clinical harms; <i>or</i> if they are the only means of protecting a patient's future autonomy from significant or irreversible impairment

Source: Blumenthal-Barby et al.⁶³ (used with permission)

Blumenthal-Barby and Burroughs⁶² outline four ethical factors to be considered in using influence strategies:

1. The greater the patient's capacity to make an autonomous choice, the less the health professional should attempt to influence the patient;
2. The less evidence concerning the efficacy of a treatment or recommendation, the less the justification for influence the patient's decision;
3. Respect for the patient's autonomy requires that the less evidence concerning a patient's long-standing values, beliefs, and goals, the less the justification for influencing a patient's decision; and
4. The greater the potential magnitude of harm relative to benefit from the attempt to influence, the less the justification for the attempt.

Current Areas of Research in Ethical and Medical Decision Making

Researchers are currently exploring ethics and medical decision making as it relates to the following areas:

- **Genetics**—The field of genomic medicine raises a number of ethical issues, including access to testing; informed consent for testing; policies related to sharing genetic testing results with patients; testing of children; use of prophylactic medications or surgery; and privacy and disclosure of test results.^{64,65}
- **End of life care**—End-of-life care raises ethical issues around withholding treatment, medical futility, and exercising the right to refuse treatment; physician-assisted suicide; shared decision making; substitute decision making; and truth telling.⁶⁶
- **Advance directives**—Advance directives are intended to uphold a patient's autonomy when he or she is unable to communicate his or her wishes. Ethical issues arise as patient's preferences change and because advance directives are unable to account for the complex situations that occur.
- **Treatment of extremely premature infants and infants with serious health conditions**—For example, ethical issues that arise when families and clinicians face clinical decisions about renal replacement therapy for infants with end-stage renal disease.⁶⁷
- **Life-sustaining therapy**—Ethical issues regarding life-sustaining treatment in the ICU and considerations of patient autonomy, protecting patients from non-beneficial treatment.⁶⁶
- **Public health**—For example, ethical issues related to required vaccination programs.



Identification of Research Gaps

The following are some research gaps related to ethical considerations in medical decision making:

- What types of interventions are most effective in improving health professionals' skills and confidence in counseling patients and families/caregivers facing difficult medical decisions, such as decisions about end-of-life or life-sustaining therapy, or decisions in which the outcomes are ambiguous or uncertain?
- What types of interventions are most effective in helping patients and families/caregivers facing difficult medical decisions, such as decisions about end-of-life decisions and life-sustaining therapy, or decisions in which the outcomes are ambiguous or uncertain?
- What are best practices for advance directives? What types of interventions maximize patient's completion of advance directives and ensure regular reviews and updates? What are the benefits of different forms of advance directions, such as changing the focus to value-driven ideals of what a patient could best hope for if they are critically ill and what they would most fear?
- What are best practices for assessing competence for participation in decision making for children and adults with cognitive limitations?

Key References

- Blumenthal-Barby, et al. (2012). Seeking better health care outcomes: The ethics of using the "Nudge." *The American Journal of Bioethics*, 12(2): 1–10.
- Ilemona, et al. (2014). An appraisal of ethical issues in end-of-life care. *Niger Journal of Medicine*, 23(4):358-64.
- Devon, et al. (2015). Ethics and genomic medicine, how to navigate decisions in surgical oncology. *Journal of Surgical Oncology*, 111(1):18-23. doi: 10.1002/jso.23771. Epub 2014 Sep 2.
- Croskerry, P., & Nimmo, G. R. (2011). Better clinical decision making and reducing diagnostic error. *The Journal of the Royal College of Physicians of Edinburgh*, 41(2), 155-162. doi: 10.4997/jrcpe.2011.208
- Reyna, V. F., Nelson, W. L., Han, P. K., & Pignone, M. P. (2015). Decision making and cancer. *Am Psychol*, 70(2), 105-118. doi: 10.1037/a0036834
- Sanfey, A. G., & Chang, L. J. (2008). Multiple systems in decision making. *Annals of the New York Academy of Sciences*, 1128(1), 53-62.

References

1. Pesendorfer W. Behavioral economics comes of age: a review essay on Advances in Behavioral Economics. *J Econ Lit.* 2006;44(3):712-721.
2. McGraw AP, Larsen JT, Kahneman D, Schkade D. Comparing gains and losses. *Psychol Sci.* 2010;21(10):1438-1445.
3. Gigerenzer G, Gaissmaier W. Heuristic Decision Making. *Annu Rev Psychol.* 2011;62(1):451-482.
4. Hauser J. A marketing science perspective on recognition-based heuristics (and the fast-and-frugal paradigm). *Judgm Decis Mak.* 2011;6(5):396-408.
5. Volpp KG, Asch DA, Galvin R, Loewenstein G. Redesigning employee health incentives: Lessons from behavioral economics. *N Engl J Med.* 2011;365(5):388-390.
6. Burns RJ, Donovan AS, Ackermann RT, Finch EA, Rothman AJ, Jeffery RW. A theoretically grounded systematic review of material incentives for weight loss: implications for interventions. *Ann Behav Med.* 2012;44(3):375-388.
7. Cabinet Office Behavioural Insights Team. Applying behavioural insight to health. London, UK; 2010.
8. Cahill K, Perera R. Competitions and incentives for smoking cessation. *Cochrane Database Syst Rev.* 2011;2011(4):CD004307.
9. Courtney MR, Spivey C, Daniel KM. Helping patients make better decisions: how to apply behavioral economics in clinical practice. *Patient Prefer Adherence.* 2014;8:1503-1512.
10. Haff N, Patel MS, Lim R, et al. The role of behavioral economic incentive design and demographic characteristics in financial incentive-based approaches to changing health behaviors: a meta-analysis. *Am J Health Promot.* 2015;29(5):314-323.
11. Mitchell MS, Goodman JM, Alter DA, et al. Financial incentives for exercise adherence in adults: systematic review and meta-analysis. *Am J Prev Med.* 2013;45(5):658-667.
12. Rice T. The behavioral economics of health and health care. *Annu Rev Public Health.* 2013;34:431-447.
13. Paul-Ebhohimhen V, Avenell A. Systematic review of the use of financial incentives in treatments for obesity and overweight. *Obes Rev.* 2008;9(4):355-367.
14. Purnell JQ. Behavioral Economics: "Nudging" Underserved Populations to Be Screened for Cancer. *Prev Chronic Dis.* 2015;12.
15. Wall J, Mhurchu CN, Blakely T, Rodgers A, Wilton J. Effectiveness of monetary incentives in modifying dietary behavior: a review of randomized, controlled trials. *Nutr Rev.* 2006;64(12):518-531.
16. Patel MS, Volpp KG. Leveraging insights from behavioral economics to increase the value of health-care service provision. *J Gen Intern Med.* 2012;27(11):1544-1547.
17. Loewenstein G, Volpp KG, Asch DA. Incentives in health: Different prescriptions for physicians and patients. *JAMA: Journal of the American Medical Association.* 2012;307(13):1375-1376.
18. Cahill K, Hartmann-Boyce J, Perera R. Incentives for smoking cessation. *Cochrane Database Syst Rev.* 2015;5:CD004307. [Epub ahead of print].
19. Centers for Medicare and Medicaid Services. Medicaid incentives for prevention of chronic diseases grants; 2011.

20. Blumenthal-Barby JS, Krieger H. Cognitive biases and heuristics in medical decision making: A critical review using a systematic search strategy. *Med Decis Making*. 2015;35(4):539-557.
21. Sanfey AG, Chang LJ. Multiple systems in decision making. *Ann N Y Acad Sci*. 2008;1128(1):53-62.
22. Thaler RH, Sunstein CR. *Nudge: Improving decisions about health, wealth, and happiness*. New Haven, CT: Yale University Press; 2008.
23. Marteau TM, Hollands GJ, Fletcher PC. Changing human behavior to prevent disease: the importance of targeting automatic processes. *Science*. 2012;337(6101):1492-1495.
24. Thaler RH, Sunstein CR, Balz JP. Choice architecture. In: Shafir E, ed. *The behavioral foundations of public policy*. Princeton, NJ: Princeton University Press; 2014:428-439.
25. Johnson EJ, Shu SB, Dellaert BG, et al. Beyond nudges: Tools of a choice architecture. *Market Lett*. 2012;23(2):487-504.
26. Dayan E, Bar-Hillel M. Nudge to nobesity II: Menu positions influence food orders. *Judgm Decis Mak*. 2011;6(4):333-342.
27. Rozin P, Scott S, Dingley M, Urbanek JK, Jiang H, Kaltenbach M. Nudge to nobesity I: Minor changes in accessibility decrease food intake. *Judgm Decis Mak*. 2011;6(4):323-332.
28. Wansink B, Hanks AS. Slim by Design: Serving Healthy Foods First in Buffet Lines Improves Overall Meal Selection. *PLoS One*. 2013;8(10):e77055.
29. Hollands GJ, Shemilt I, Marteau TM, et al. *Altering choice architecture to change population health behaviour: a large-scale conceptual and empirical scoping review of interventions within micro-environments*. Cambridge, MA: University of Cambridge; 2013.
30. Johnson EJ, Goldstein DG. Defaults and Donation Decisions. *Transplantation*. 2004;78(12):1713-1716.
31. Nease RF, Frazee SG, Zarin L, Miller SB. Choice architecture is a better strategy than engaging patients to spur behavior change. *Health Aff (Millwood)*. 2013;32(2):242-249.
32. Schweitzer M, Hershey JC, Asch DA. Individual choice in spending accounts. Can we rely on employees to choose well? *Med Care*. 1996;34(6):583-593.
33. Allcott H, Rogers T. The Short-Run and Long-Run Effects of Behavioral Interventions: Experimental Evidence from Energy Conservation. *Am Econ Rev*. 2014;104(10):3003-3037.
34. Johnson EJ, Hassin R, Baker T, Bajger AT, Treuer G. Can Consumers Make Affordable Care Affordable? The Value of Choice Architecture. *PLoS One*. 2013;8(12):e81521.
35. Bansback N, Li LC, Lynd L, Bryan S. Development and preliminary user testing of the DCIDA (Dynamic computer interactive decision application) for 'nudging' patients towards high quality decisions. *BMC Med Inform Decis Mak*. 2014;14:62.
36. Dubov A, Phung C. Nudges or mandates? The ethics of mandatory flu vaccination. *Vaccine*. 2015;33(22):2530-2535.
37. Oppenheimer DM, Kelso E. Information processing as a paradigm for decision making. *Annu Rev Psychol*. 2015;66:277-294.
38. Johnson EJ, Weber EU. Mindful judgment and decision making. *Annu Rev Psychol*. 2009;60:53.
39. Johnson JG, Busemeyer JR. A dynamic, stochastic, computational model of preference reversal phenomena. *Psychol Rev*. 2005;112(4):841-861.

40. Busemeyer JR, Townsend JT. Decision field theory: a dynamic-cognitive approach to decision making in an uncertain environment. *Psychol Rev.* 1993;100(3):432-459.
41. Usher M, McClelland JL. The time course of perceptual choice: the leaky, competing accumulator model. *Psychol Rev.* 2001;108(3):550-592.
42. Stewart N, Chater N, Brown GD. Decision by sampling. *Cogn Psychol.* 2006;53(1):1-26.
43. Schneider AS, Oppenheimer DM, Detre GJ. Application of voting geometry to multialternative choice. *Proceedings of the 29th Annual Conference of the Cognitive Science Society.* Mahwah, NJ: Erlbaum; 2007:635-640.
44. Thagard PR. Explanatory coherence. *Behav Brain Sci.* 1989;12:435-502.
45. Simon D, Krawczyk DC, Holyoak KJ. Construction of preferences by constraint satisfaction. *Psychol Sci.* 2004;15(5):331-336.
46. Evans JST, Stanovich KE. Dual process theories of higher cognition: Advancing the debate. *Perspectives in Psychological Science.* 2013;8(3):223-241.
47. Sheeran P, Gollwitzer PM, Bargh JA. Nonconscious processes and health. *Health Psychol.* 2013;32(5):460.
48. Kahneman D. *Thinking, fast and slow:* Macmillan; 2011.
49. Dolan P, Hallsworth M, Halpern D, King D, Metcalfe R, Vlaev I. Influencing behaviour: The mindspace way. *J Econ Psychol.* 2012;33(1):264-277.
50. Reyna VF. A theory of medical decision making and health: fuzzy trace theory. *Med Decis Making.* 2008.
51. Kahan DM. Two conceptions of emotion in risk regulation. *University of Pennsylvania Law Review.* 2008:741-766.
52. Croskerry P. Diagnostic decision making process model. Received via email by Katherine Treiman, RTI International, May 2015.
53. Djulbegovic B, Hozo I, Beckstead J, Tsalatsanis A, Pauker SG. Dual processing model of medical decision-making. *BMC Med Inform Decis Mak.* 2012;12:94-94.
54. Smith SG, Raine R, Obichere A, Wolf MS, Wardle J, von Wagner C. The effect of a supplementary ('gist-based') information leaflet on colorectal cancer knowledge and screening intention: a randomized controlled trial. *J Behav Med.* 2015;38(2):261-272.
55. Reyna VF, Mills BA. Theoretically Motivated Interventions for Reducing Sexual Risk Taking in Adolescence: A Randomized Controlled Experiment Applying Fuzzy-Trace Theory. *J Exp Psychol-Gen.* 2014;143(4):1627-1648.
56. Monteiro SM, Norman G. Diagnostic reasoning: where we've been, where we're going. *Teach Learn Med.* 2013;25 Suppl 1:S26-32.
57. Pesseau J, Johnston M, Heponiemi T, et al. Reflective and Automatic Processes in Health Care Professional Behaviour: a Dual Process Model Tested Across Multiple Behaviours. *Ann Behav Med.* 2014;48(3):347-358.
58. Elwyn G, Stiel M, Durand MA, Boivin J. The design of patient decision support interventions: addressing the theory–practice gap. *J Eval Clin Pract.* 2011;17(4):565-574.
59. Gillon R. Medical ethics: four principles plus attention to scope. *BMJ.* 1994;309(6948):184-188.
60. Vallgård S. Nudge—A new and better way to improve health? *Health Policy.* 2012;104:200-203.

61. Devisch I. Progress in medicine: autonomy, oughtonomy and nudging. *J Eval Clin Pract.* 2011;17(5):857-861.
62. Blumenthal-Barby JS, Burroughs H. Seeking better health care outcomes: the ethics of using the "nudge". *Am J Bioeth.* 2012;12(2):1-10.
63. Blumenthal-Barby JS, McCullough LB, Krieger H, Coverdale J. Methods of influencing the decisions of psychiatric patients: an ethical analysis. *Harv Rev Psychiatry.* 2013;21(5):275-279.
64. Devon KM, Lerner-Ellis JP, Ganai S, Angelos P. Ethics and genomic medicine, how to navigate decisions in surgical oncology. *J Surg Oncol.* 2015;111(1):18-23.
65. McGuire AL, Joffe S, Koenig BA, et al. Ethics and genomic incidental findings. *Science.* 2013;340(6136):1047-1048.
66. Godfrey G, Hilton A, Bellomo R. To treat or not to treat: withholding treatment in the ICU. *Curr Opin Crit Care.* 2013;19(6):624-629.
67. Lantos JD, Warady BA. The evolving ethics of infant dialysis. *Pediatr Nephrol.* 2013;28(10):1943-1947.

Appendix C: Meeting Agenda

Advancing Medical Decision-Making PCORI Expert Meeting

June 4, 2015, 8:00 a.m. – 4:00 p.m. EST
The Melrose Georgetown Hotel
2430 Pennsylvania Avenue NW, Washington, DC 20037

8:00 – 8:30 a.m.	Breakfast	
8:30 – 9:00 a.m.	Welcome, Introductions, and Meeting Goals	Dave Flum Mark Helfand David Meltzer Bill Lawrence
9:00 – 10:30 a.m.	<p>1. Decisions In and Out of Health <i>How are health-related decisions the same/different as other types of decisions (e.g., consumer decisions, financial decisions)? What are the strengths and limitations of current decision-making models for addressing these differences?</i></p>	Valerie Reyna Ellen Peters Jon Baron Comments: Val Simianu Moderator: Mark Helfand
10:30 – 10:45 a.m.	Break	
10:45 a.m. – 12:00 p.m.	<p>2. New Developments in Psychology and Decision Making <i>What new developments in behavioral economics and the psychology of decision-making hold promise to be applicable to healthcare choices and to improve medical decision-making?</i></p>	Brian Zikmund-Fisher Nidhi Agarwal Moderator: David Meltzer
12:00 – 12:45 p.m.	<p>3. Working Lunch and Discussion <i>What are key ethical considerations in medical decision-making? What practical and moral issues should be considered with use of behavioral economics, choice architecture, and decisional psychology (e.g., framing effects, default options, incentives, focusing effects, commitment contracts and subconscious priming) to shape people’s medical decisions and behaviors?</i></p>	Angie Fagerlin Moderator: Bill Lawrence
12:45 – 2:15 p.m.	<p>4. Choice Architecture and Behavioral Economics <i>What is the potential of choice architecture in the context of healthcare? What are the limitations?</i></p>	Eric Johnson Scott Halpern Jennifer Blumenthal-Barby Moderator: Dave Flum
2:15 – 2:30 p.m.	Break	
2:30 – 3:30 p.m.	<p>5. Facilitated Discussion: Priority Research Questions as Applied to Healthcare Decision-Making <i>What are the barriers to entry into healthcare research for researchers working in decision-making in other areas? What are the gaps that these researchers can address that would demonstrate the advantage of the addition of these paradigms to our current medical decision-making framework? What are possible priority research questions for the application of new decision-making developments to healthcare decision-making?</i></p>	Moderators: Dave Flum Bill Lawrence
3:30 – 4:00 p.m.	Next Steps and Adjourn	

Appendix D: Slide Presentations

Advancing Medical Decision Making: PCORI Expert Meeting

William Lawrence, MD, MS

Senior Program Officer

Communication and Dissemination Research

June 4, 2015



PATIENT-CENTERED OUTCOMES RESEARCH INSTITUTE

About Us

- An independent research institute authorized by Congress in 2010 and governed by a 21-member Board of Governors representing the entire healthcare community
- Funds comparative clinical effectiveness research (CER) that engages patients and other stakeholders throughout the research process
- Seeks answers to real-world questions about what works best for patients based on their circumstances and concerns



From the Legislation

“The Institute shall establish a standing methodology committee to...develop and improve the science and methods of comparative clinical effectiveness research.”



Our Broad and Complex Mandate

“The purpose of the Institute is to **assist patients, clinicians, purchasers, and policy-makers in making informed health decisions** by advancing the quality and relevance of evidence concerning the manner in which diseases, disorders, and other health conditions can effectively and appropriately be prevented, diagnosed, treated, monitored, and managed **through research and evidence synthesis...**

... and the dissemination of research findings with respect to the relative health outcomes, clinical effectiveness, and appropriateness of the medical treatments, services...”

--from PCORI's authorizing legislation



We Fund CER

Research that....

- Generates and synthesizes evidence comparing benefits and harms of at least two different methods to prevent, diagnose, treat, and monitor a clinical condition or improve care delivery
- Measures benefits in real-world populations
- Informs a specific clinical or policy decision
- Describes results in subgroups of people
- Applies appropriate methods and data sources
- Helps consumers, clinicians, purchasers, and policy makers make informed decisions that will improve care for individuals and populations



Adapted from *Initial National Priorities for Comparative Effectiveness Research*, Institute of Medicine of the National Academies



Our National Priorities for Research

Assessment of Prevention, Diagnosis, and Treatment Options

Research that:

- Compares the effectiveness and safety of alternative prevention, diagnosis, and treatment options
- Determines which ones work best for different people with a particular health problem



Our National Priorities for Research

Assessment of Prevention,
Diagnosis, and Treatment
Options

Improving Healthcare Systems

Research that:

- Compares health system–level approaches to improving access
- Supports patient self-care, innovative use of health information technology, care coordination for complex conditions, and effective workforce deployment



Our National Priorities for Research

Assessment of Prevention,
Diagnosis, and Treatment
Options

Improving Healthcare Systems

**Communication and
Dissemination Research**

Research on:

- Providing information produced by CER
- Empowering people to ask for and use the information
- Supporting shared decision making between patients and their providers



Our National Priorities for Research

Assessment of Prevention,
Diagnosis, and Treatment
Options

Improving Healthcare Systems

Communication and
Dissemination Research

Addressing Disparities

Research on:

- Prevention, diagnosis, or treatment effectiveness
- Preferred clinical outcomes across patient populations
- Health care required to achieve best outcomes in each population



Our National Priorities for Research

Assessment of Prevention,
Diagnosis, and Treatment
Options

Improving Healthcare Systems

Communication and
Dissemination Research

Addressing Disparities

**Accelerating Patient-Centered
Outcomes Research and
Methodological Research**

Research on:

- Building data infrastructure
- Improving analytic methods
- Training researchers, patients, and other stakeholders to participate in this research



Snapshot of Funded Projects

Number of projects:

400

Amount awarded:

\$868.8 million

Number of states where
we are funding research:

39 (plus the District of Columbia)

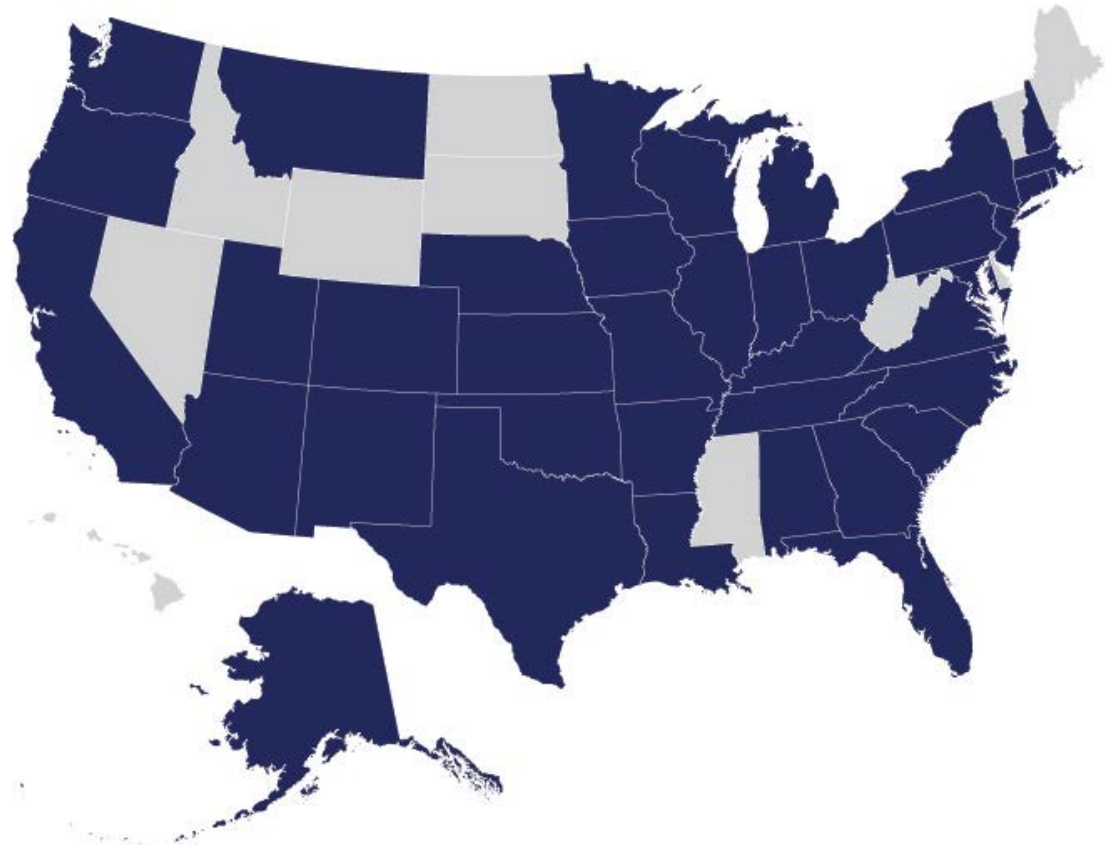

As of April 21, 2015



For Today's Meeting

- The PCORI Methodology Committee is interested in advancing PCORI's understanding of new approaches to improve decision making
- Interested in a broad range of decisions
 - Preference-Sensitive and Non-Preference-Sensitive
 - Patient, Caregiver, and Clinician (and potentially combinations) as decision makers



You Can Help Us!

- Identify established and emerging areas of research that may help with decision making and behavior change
- Salient literature
- What are the gaps that new research could help address?
- Are there established but underutilized approaches that would fit within the context of comparative effectiveness research (eg. some efficacy data, next step being testing in a comparative effectiveness approach)?



Housekeeping

- People listening on the phone – please use microphone
- Final RTI report based upon this meeting will be publicly posted
- Your talk will be summarized and attributed, but points in discussion will not be identified



Normative, descriptive, and prescriptive models

Jonathan Baron

6/4/2015

Normative models

Standards for evaluation of judgments and decisions.

Not justified empirically. Can be justified by philosophical argument.

Examples:

- ▶ Right answer: logic, arithmetic, factual questions, test items
- ▶ Coherence (internal consistency)
 - ▶ Additivity of probability
 - ▶ Principles of choice: transitivity, independence, dynamic consistency
- ▶ Correspondence: calibration of probability, Brier score, judgment accuracy, dominance
- ▶ Other features of probability and utility, e.g., additivity across people (utilitarianism)

Descriptive models

Phenomena and their explanations. From psychology.

Types and examples:

- ▶ process models: diffusion models (accumulator, DFT), two-system (default-interventionist, parallel-competitive)
- ▶ paramorphic models: social judgment theory (regression models of judgment), hyperbolic discounting
- ▶ heuristics: availability (what is “on screen”, isolation effect); attribute substitution (imperfect correlations); myside bias; motivated reasoning
- ▶ psychophysical distortions (diminishing sensitivity)

Prescriptive models

Ways to improve judgments and decisions according to the normative standards. From engineering in the broad sense. Designs.

Types and examples:

- ▶ Decision analysis and decision aids (decision analysis in cans)
- ▶ Behavioral manipulations, nudges, choice architecture
- ▶ Communication
- ▶ Education, teaching (e.g., AOT), specific debiasing

Example 1: omission bias

A vaccine causes the disease it prevents. Without it, you have a 20% chance of the disease. With it, 5%, caused by the vaccine.

A vaccine causes the disease it prevents. Without it, 20% of the population get the disease. With it, 5% get it, caused by the vaccine.

Normative models: expected utility; utilitarianism.

Descriptive models: many, but one is confusion of physical causality with but-for causality.

Example 2: proportionality

Two correlated attributes of probability: probability difference, frequency ratio.

People sometimes attend to one when they should attend to the other according to probability theory and expected-utility theory. These are attribute-substitution heuristics.

Ratio bias or denominator neglect is attention to frequency when probability is relevant, e.g., 9/100 vs. 1/10 urns!

Proportionality bias is attention to ratios when differences are relevant.

E.g., an intervention doubles the probability of X but reduces the probability of Y by 10%. X and Y are about equally serious. Specifically X goes from 1% to 2%. Y goes from 50% to 45%. People still think the treatment is bad.

Prescription: stop reporting relative risk.

Fuzzy Trace Theory: Explaining and Predicting Medical Decision Making Across the Lifespan

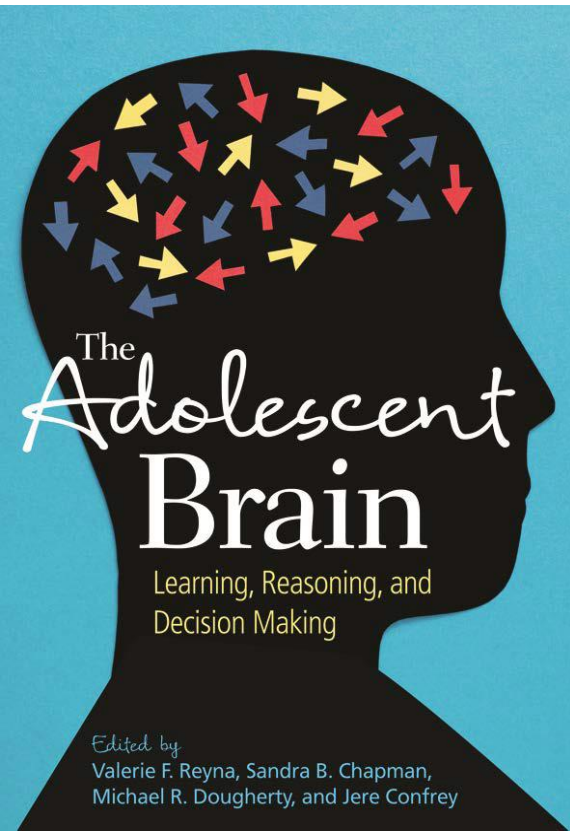
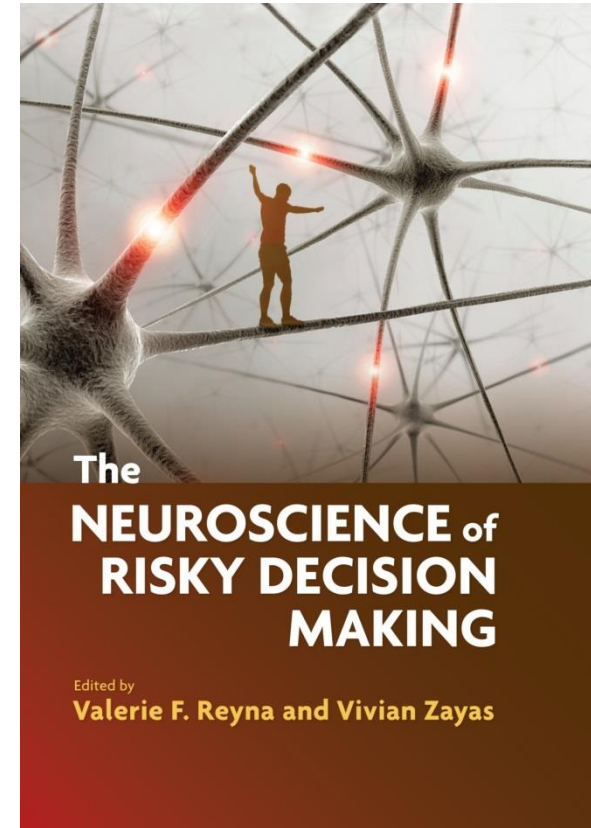

Valerie F. Reyna
Cornell University

PCORI Expert Panel on Priorities for
Research in Medical Decision Making

June 4, 2015

Approaches to Decision Making

- Behavioral Economics
 - Expected utility and variations (PT and CPT)
 - Incentives are good but they are not everything
 - Do not improve discrimination (d') and can lower accuracy
- Psychology
 - Prospect theory (and CPT)
 - Dual-process theories
 - Emotion vs. cognition
 - Fast vs. slow: Heuristics and biases
 - Intuition vs. deliberation
 - Recent “patches” that do not repair
 - Fuzzy-trace Theory

Fuzzy-trace Theory

(*Fuzzy* traces are gist representations.)

Fuzzy Trace Theory

Verbatim
Encodes
and
processes
surface
details



Gist
Encodes
and
processes
bottom-
line
meaning

Information: Children whose parents refused the vaccine were 23 times more likely to get disease.

Verbatim:
23 times more
likely.

Gist:
Increase in risk
is huge.



Reyna, 2012,
Vaccine

Mental Representations

- ***Gist*** representation
 - Bottom-line *meaning* of information
 - Vague and qualitative
 - Interpretation based on emotion, education, culture, experience, worldview, numeracy
- ***Verbatim*** representation
 - Exact surface form (literal)
 - Precise and quantitative
- Not just words and narratives, extended to numbers, graphs, pictures, events...
- Take home message: People do not decide solely based on literal incentives (reinforcement)—the subjective meaning of decision options is pivotal.

Different Representations Support Different Decision Processes

- Verbatim representations
 - Sufficient detail to support analysis
- Gist representations (essential meaning)
 - Support intuition (fuzzy, parallel, impressionistic, usually unconscious processing)
- Different ways of processing information.



Differs from Standard Dual Processes

- Fuzzy gist-based reasoning is:
 - Parallel and independent of verbatim
 - Not standard serial and dependent
 - *Increases* with advanced development
 - Experience and expertise
 - Developmental reversals (e.g., Brainerd & Reyna, 2012; Reyna & Lloyd, 2006; Reyna, Chick, Corbin, & Hsia, 2014)
 - Differs from “heuristics” in that not just processing less--not just taking shortcuts
 - Source of *semantic* heuristics and biases
 - Not meaningless association or impulse

Theory-driven Applications

- Fraenkel et al. (2012)
 - Patients, many middle-aged and older
 - Value-concordant decisions from 35% to 64%
- Reyna & Mills (2014)
 - 734 teens RCT for pregnancy/HIV prevention
 - 12 outcomes at one-year follow-up
- Broniatowski, Klein, & Reyna (2015).
 - Germs are germs, and why not take a risk?: Patients' expectations for prescribing antibiotics in an inner city emergency department
- Wolfe et al. (2015)
 - Breast cancer and genetic risk RCT
 - Genetic testing from about 50% to < 25%

5 A's in Neurodevelopment

Gist

		Low	High
Verbatim	Low	Alzheimer's	Aged
	High	Autism	Adults (Young)

Adolescents

Descriptive, Normative, and Prescriptive Views

- What people do
 - Lack knowledge (medical and numeracy), rely on gist, fail to retrieve their core values when relevant, and become bogged down when they deal with ratios (e.g., false positives)
- What theories say?
 - Normative theories are useful
 - Violations of logic and probability theory
- How can we improve?
 - What increases with development, expertise, and experience?
 - More illogical and more violations of probability theory
 - What facilitates real-world decision making?

Why is gist-based intuition often health-promoting?

- More fine-grained, quantitative has ironic effect
 - Trading off increases risk taking because trading off risks and benefits often objectively favors risk taking
 - Especially for single acts as opposed to many acts
 - “It won’t happen to me”
 - Verbatim thinking promotes unhealthy risk-taking because the benefits often high while risks are often low, producing a *rational calculus of risk promotion*.
- Global gist is protective.

Why say gist is “advanced”?

- Teens more distinctions than adults re: trying drugs (Reyna & Farley, 2006)
 - $0X < 1X < 2X...$
- As expertise in cardiology increases, fewer dimensions processed, better decisions (Reyna & Lloyd, 2006); also agents
- Teens who endorse “Less risk is better than more risk” vs. “No risk is better than some risk” are > twice as likely to be sexually active: 61% vs. 30% (Mills, Reyna, & Estrada, 2008; Reyna et al., 2011).
- Reliance on gist ↑ from childhood to adulthood
 - “False” memories
 - Heuristics and biases

Gaps in Knowledge in Medical Decision Making

- Meaning and memory representations
 - Categories and cutpoints
 - Narratives
- Emotion and values
 - Need to build on predictive theory
- Developmental differences
- Individual differences
- More emphasis on cumulative knowledge, scientific prediction, and disconfirmation

Take-Home Messages

- Developmental differences in mental representation—verbatim vs. gist—from childhood to old age
 - Verbatim and gist increase from childhood to adulthood
 - JDM preferentially relies on gist in adulthood
 - Verbatim decreases in old age; gist preserved
- Lab tasks load on verbatim, real life loads on gist
- Gist-based JDM generally promotes healthier outcomes
 - Measurement and manipulation (pre-post, RCTs)

References

- Brainerd, C. J., Reyna, V. F., Gomes, C. F. A., Kenney, A. E., Gross, C. J., Taub, E. S., Spreng, R. N., & Alzheimer's Disease Neuroimaging Initiative. (2014). Dual-retrieval models and neurocognitive impairment. *Journal of Experimental Psychology: Learning, Memory, and Cognition*, *40*(1), 41-65. doi: 10.1037/a0034057
- Broniatowski, D. A., Klein, E. Y., & Reyna, V. F. (2015). Germs are germs, and why not take a risk?: Patients' expectations for prescribing antibiotics in an inner city emergency department. *Medical Decision Making*, *35*, 60-67. doi: 10.1177/0272989X14553472
- Fraenkel, L., Peters, E., Charpentier, P., Olsen, B., Errante, L., Schoen, R. T., & Reyna, V. (2012). Decision tool to improve the quality of care in rheumatoid arthritis. *Arthritis Care & Research*, *64*, 977–985. doi:10.1002/acr.21657
- Reyna, V. F. (2008). A theory of medical decision making and health: Fuzzy-trace theory. *Medical Decision Making*, *28*, 850–865. doi:10.1177/ 0272989X08327066
- Reyna, V. F. (2012). A new intuitionism: Meaning, memory, and development in fuzzy-trace theory. *Judgment and Decision Making*, *7*(3), 332–359.
- Reyna, V. F., & Brainerd, C. J. (2011). Dual processes in decision making and developmental neuroscience: A fuzzy-trace model. *Developmental Review*, *31*, 180–206. doi:10.1016/j.dr.2011.07.004

References-continued

- Reyna, V. F., Chick, C. F., Corbin, J. C., & Hsia, A. N. (2014). Developmental reversals in risky decision-making: Intelligence agents show larger decision biases than college students. *Psychological Science, 25*, 76–84. doi:10.1177/0956797613497022
- Reyna, V. F., & Mills, B. A. (2014). Theoretically motivated interventions for reducing sexual risk taking in adolescence: A randomized controlled experiment using fuzzy-trace theory. *Journal of Experimental Psychology: General, 143* (4),1627 1648. doi:[10.1037/a0036717](https://doi.org/10.1037/a0036717)
- Reyna, V. F., Nelson, W. L., Han, P. K., & Pignone, M. P. (2015). Decision making and cancer. *American Psychologist, 70*(2), 105-118. doi: 10.1037/a0036834
- Reyna, V. F., & Zayas, V. (2014). *The neuroscience of risky decision making*. Washington, DC: American Psychological Association.
- Wolfe, C. R., Reyna, V. F., Widmer, C. L., Cedillos, E. M., Fisher, C. R., Brust-Renck, P. G., & Weil, A. M. (2015). Efficacy of a Web-based intelligent tutoring system for communicating genetic risk of breast cancer: A fuzzy-trace theory approach. *Medical Decision Making, 35*, 46-59. doi: 10.1177/0272989X14535983.

Thank you!

PCORI

NIH (OppNet and NINR)

My students, staff, and postdocs

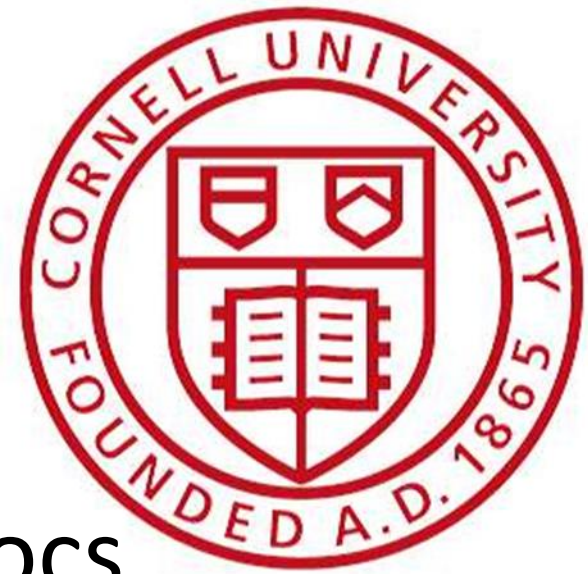

Postscript

Reward and Inhibition in Adolescence: Galvan (2012); Somerville, Jones, & Casey (2010)

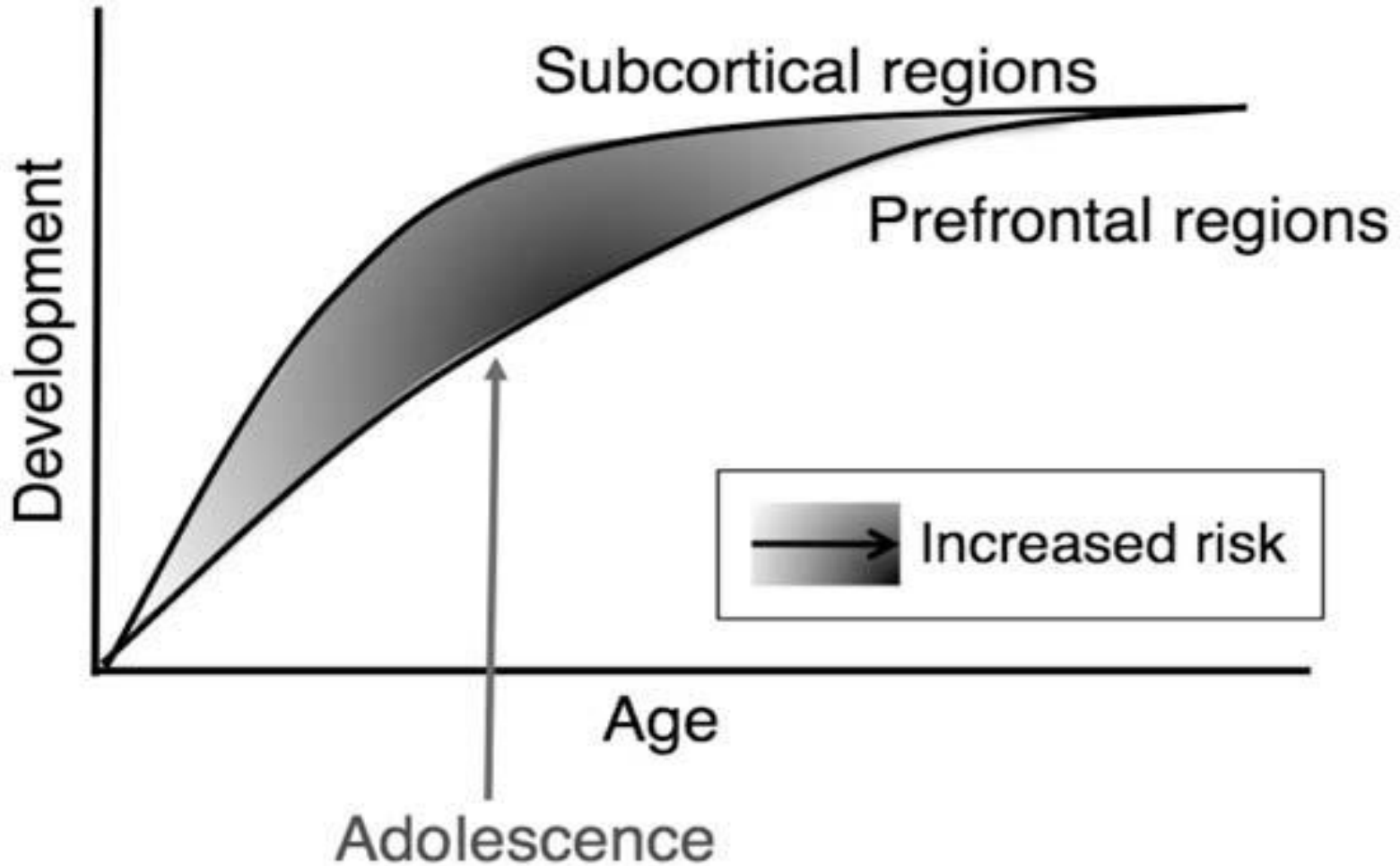

Age: Go (Reward) vs. Stop (Inhibition)

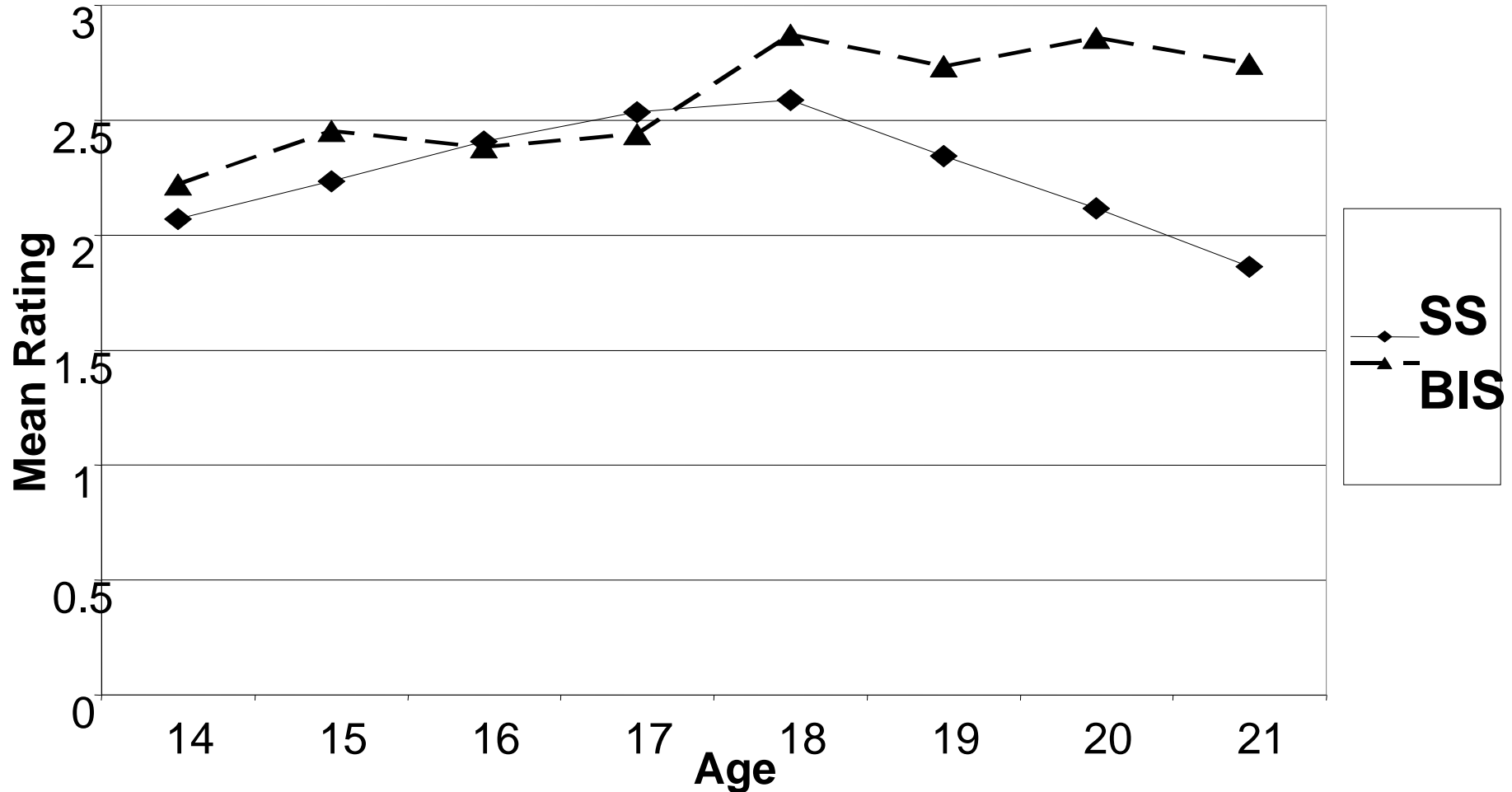

Reyna, Estrada, DeMarinis, Myers, Stanisiz, & Mills (2011)

Developmental Reversal: Adolescents vs. Adults

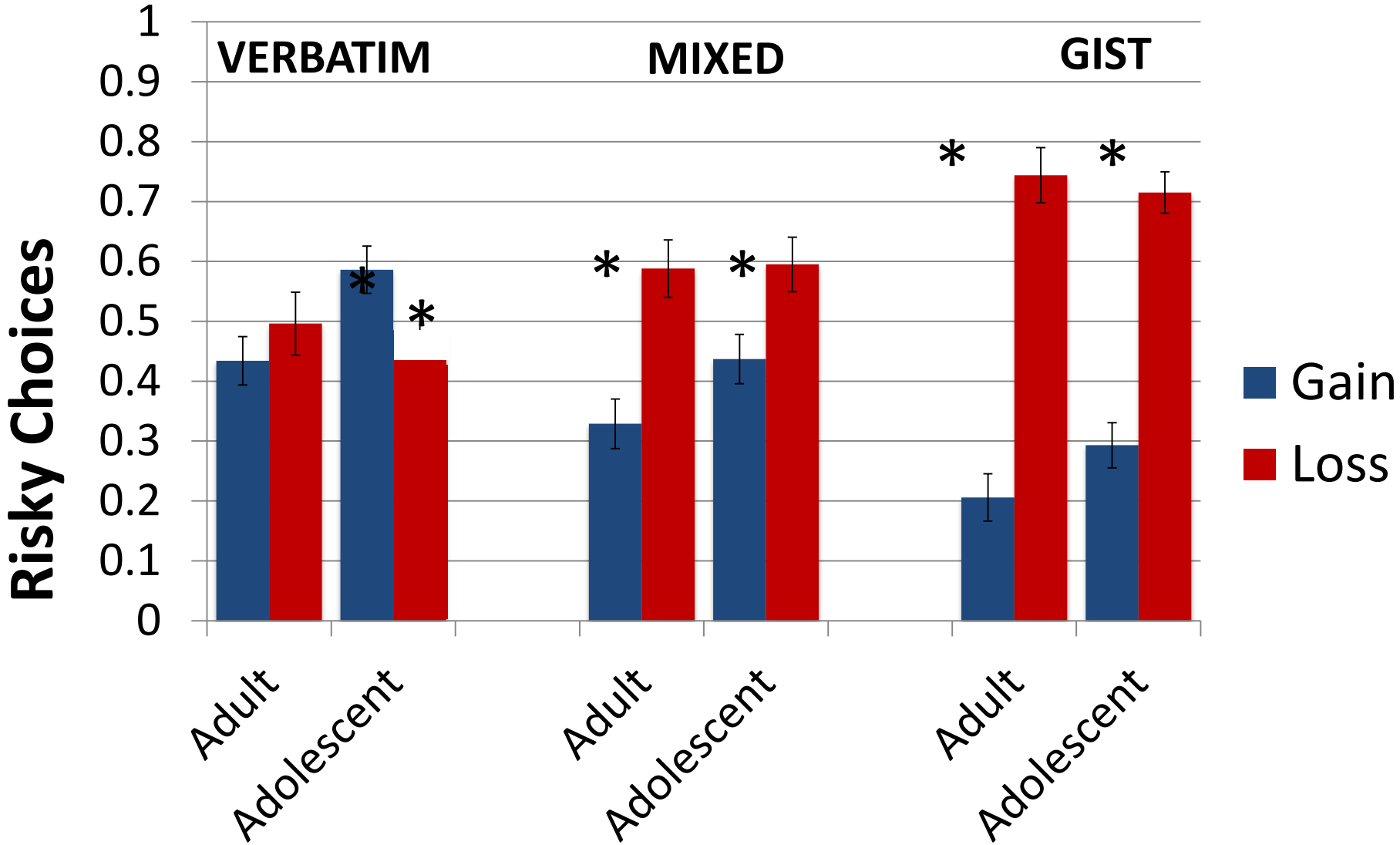

If gist causes framing bias, people with autism spectrum disorders (ASD) should be less subject to framing bias.
(high verbatim, low gist)

DeMartino et al. (2008): ASD

Susceptibility to the Framing effect

Subjects' risk attitude

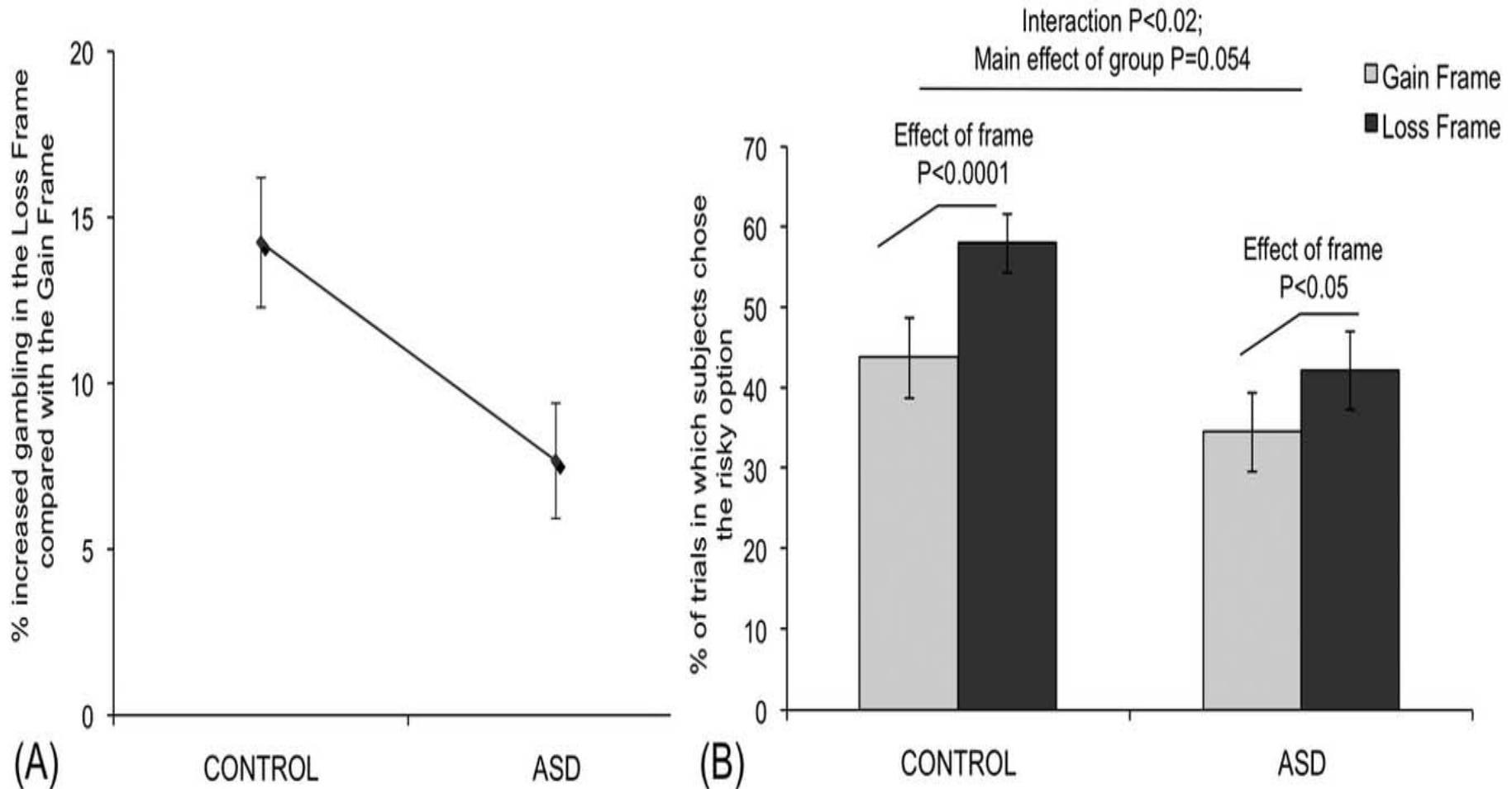

See also, Morsanyi, Handley, & Evans, 2010

Memory: Childhood to Old Age (and Alzheimer's)

Estimates of Verbatim Readout, Gist Reconstruction, and Gist Familiarity in Recall of Word Lists Across Groups

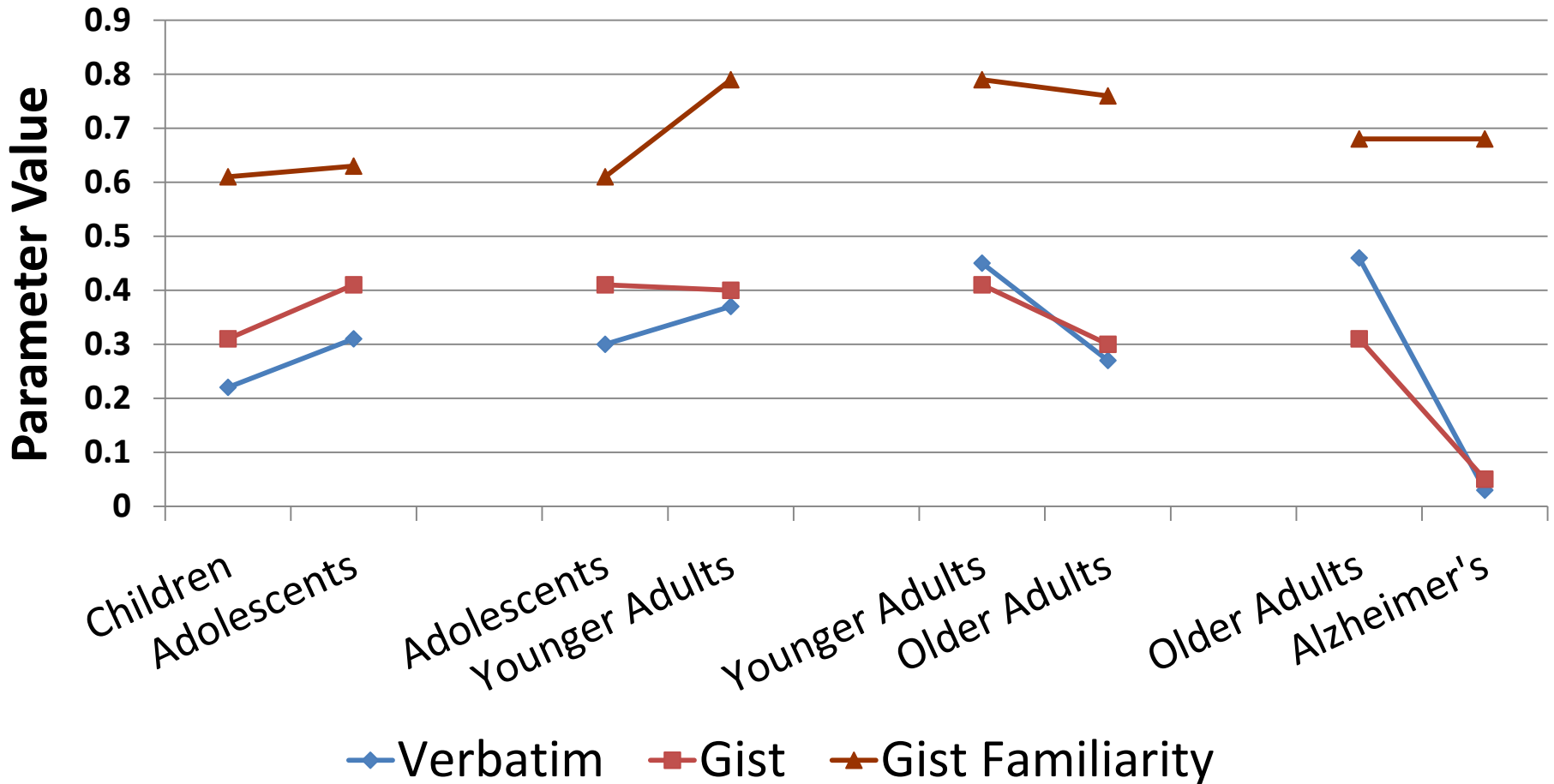

Judgments and Decisions

- **Stored Knowledge and Values**
 - What you know and value:
Education and experience
- **Mental Representations**
 - Verbatim = Literal representation of situation
 - Gist = How perceive (understand) the situation
- **Retrieval of Knowledge/Values**
 - How access what you know and value in the situation
- **Implementation**
 - How put together what you perceive with what you know to make judgments and decisions
- **Inhibition and Self-Control**

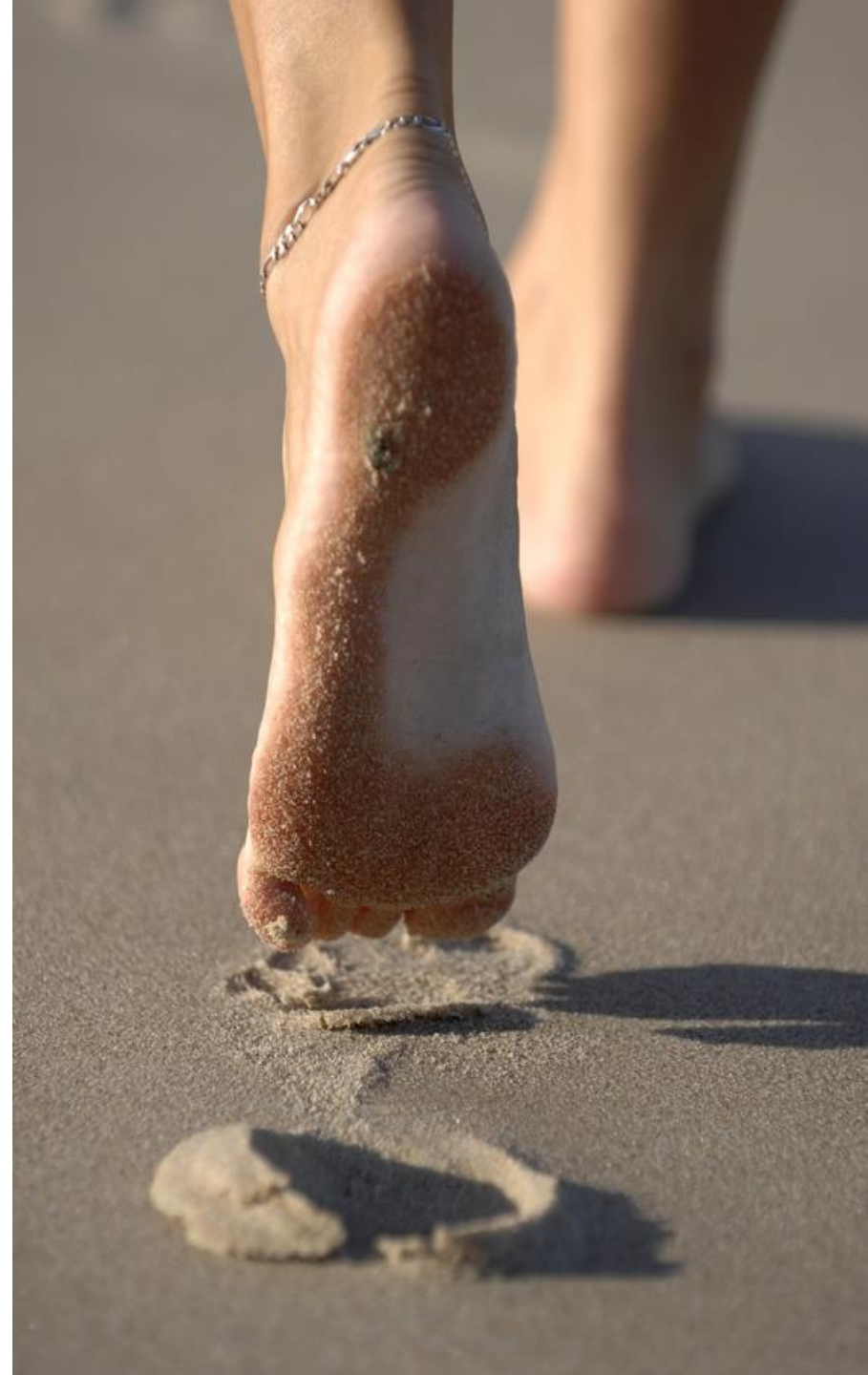

The psychology of number processing in decisions

Ellen Peters, Ph.D.
Professor of Psychology
Director, Decision Sciences Collaborative



Modern man lives under a tyranny of numbers (Eberstadt, 1995, p. 1)

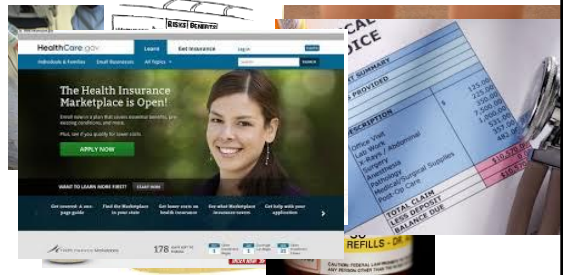

2



Numbers in health

- Numbers instruct, inform, give meaning to information about health plans, medications, and treatments
- But not all people can understand and use numbers effectively
 - Even highly educated can be innumerate
- This innumeracy influences comprehension and use of information
 - How information is presented can help

3



A common patient task

(National Assessment of Adult Literacy or NAAL)

John forgot to take his medicine before lunch at 12:00 noon and now has to figure out when to take it. His prescription bottle says:

“Take one tablet on an empty stomach one hour before a meal or two to three hours after a meal unless otherwise directed by your doctor”

What is the earliest time he can take it in the afternoon?

Correct answers:

2pm, 2-3pm, or 2 hours after

4



- How many people in the U.S. answered that question correctly?

~60%

- This is a numeracy issue
- It's also a communication issue

5



Numeracy skill levels in the U.S.

- Americans have limited numeracy skills
- Disparities exist
 - age, education, income, gender
 - having pre-ACA health insurance (Peters, Meilleur, & Tompkins, 2014)
- OECD estimated the proportion of Americans who fell into five numeracy performance levels

6

OECD U.S. 2013: Key abilities		
Numeracy Level	% adults	Key abilities associated with level
Below Level 1	9%	Simple processes: counting, sorting, using whole numbers or money. Little or no text or distractors.
Level 1	20%	Basic one-step or simple processes (counting, sorting, simple arithmetic, simple percents such as 50% Little text and minimal distractors.
Level 2	33%	More complicated math with two+ steps, percents and fractions, simple measurement, estimation; simple tables and graphs.
Level 3	26%	Less explicit and unfamiliar numeric tasks that require several steps, problem solving, interpretation and basic analysis of data and statistics in texts, tables and graphs
Level 4/5	9%	Complex, abstract, unfamiliar contexts. Multiple steps, analysis, statistics and chance, change, formulas.



Why is numeracy important? Outcomes

- Innumeracy associated with:
 - less informed choice
 - more hospital and emergency room visits
 - lower likelihood to quit smoking
 - less ability to follow complex medication regimens (Coumadin for stroke risk; HIV medications)
 - fewer protective health behaviors (e.g., HIV)
 - higher hemoglobin A1c levels

8



Numeracy and psychological mechanisms (that influence risk perceptions and decisions)

- Comprehension (lots of cites)
- Attention to numbers (e.g., Keller, 2011)
- Framing effects and transforming numbers

9



Probability and Frequency in Risk Communication

1% chance
vs.
1 out of 100

- Are they the same or different risk?
- Are they the same or different in communicating risk?

10



Frequencies have greater impact than percentages (e.g., on risk perceptions)

- Among experts judging dangerousness of a mental patient (Slovic et al., 2000)
- Across domains and especially among the less numerate
 - Dangerousness of mental patient (Peters et al., 2006)
 - Medication risk perceptions (Peters et al., 2011)
 - Terrorism risk perceptions (Dieckmann et al., 2009)
 - Donation behaviors (Dickert et al., 2011)

11



Numeracy and psychological mechanisms (that influence risk perceptions and decisions)

- Comprehension
- Attention to numbers
- Framing effects and transforming numbers
- Affective meaning drawn from numbers and number comparisons (e.g., Peters et al., 2006; Petrova et al., 2013; Kleber et al., 2013)
- How much numeric information is used
- Influence of non-numeric information

12



Use of numeric and non-numeric information

- Highly numerate use numbers more:
 - Benefits of adjuvant treatment for breast cancer (Lipkus et al., 2010)
 - Terrorism risk perceptions (Dieckmann et al., 2009)
- Less numerate use non-numeric info more
 - Frame of provided information
 - Narratives (Dieckmann et al., 2009)
 - Moods (Peters et al., 2009; Vastfjall et al., in prep)

13



How can providers and others communicate with those with lower numeracy skills?

14



Evidence-based strategies for communication

(Peters et al., 2014, IOM)

1. Provide numeric information (as opposed to not providing it)
 - Prescription drugs. Interpret risks more accurately and more willing to take a medication (Peters et al., 2014)
 - Physician communication. More likely to communicate prognostic information (Han et al., in prep)
 - Climate change.
 - More accurate risk interpretations (Budescu et al., 2014)
 - Increases estimates of scientific agreement that climate change is human caused (Myers et al., 2015)

Effects are generally stronger for more numerate

15



Evidence-based strategies for communication

(Peters et al., 2014, IOM)

2. Reduce the cognitive effort required from the patient or consumer
 - Provide fewer options
 - Provide less information

16



Evidence-based strategies for communication

(Peters et al., 2014, IOM)

2. Reduce the cognitive effort required from the patient or consumer
 - Provide fewer options
 - Provide less information
 - Do the math for them
 - Keep denominators and time spans constant
 - Use numbers consistent with how people use the number line
 - Present absolute risks, not just relative risks
 - Use appropriate visuals (Garcia-Retamero & Cokely, 2013)

Effects are generally stronger for less numerate

17



Evidence-based strategies for communication

(Peters et al., 2014, IOM)

3. Provide evaluative meaning to increase use of numeric information, particularly when numeric information is unfamiliar
 - Carefully use evaluative labels and symbols
 - Carefully use frequency vs percentage formats

18

0 Evidence-based strategies for communication (Peters et al., 2014, IOM)

3. Provide evaluative meaning, particularly when numeric information is unfamiliar
 - Carefully use evaluative labels and symbols
 - Carefully use frequency versus percentage formats
 - Use other more imaginable data formats



 40 minutes
brisk walking

19

0 Evidence-based strategies for communication (Peters et al., 2014, IOM)

4. Draw attention to important information
 - Order information with the most important information first or last
 - Highlight the meaning of only the most important information
 - Use a framework to provide an overview
 - Use fonts that draw attention to important information

20

0 Summary of evidence-based communication strategies (Peters et al., 2014, IOM)

1. Provide numeric information (as opposed to not providing it)
2. Reduce the cognitive effort required from the patient or consumer and require fewer inferences (i.e., do the math for them)
3. Provide evaluative meaning, particularly when numeric information is unfamiliar
4. Draw attention to important information

21

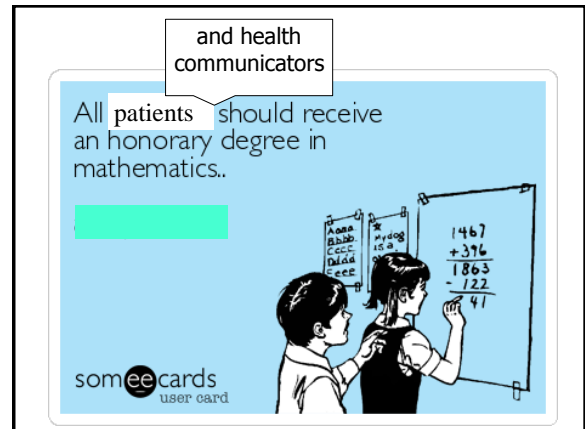

0 Conclusions

1. Consumers have difficulty with complex numeric information important to good health decisions
 - Effects similar across domains
2. We know a lot about evidence-based communication techniques
 - Effects similar across domains
3. Patient communication should be strategic
 - Decide what the communication goals are
 - And then carefully choose in an evidence-based manner how to present information

23

0 Possible new directions

1. Different ways to be “numerate” may be important to health (Peters & Bjalkbring, 2015, *JPS*; Schley & Peters, 2014, *PsychScience*)
 - Objective numeracy (Math test)
 - Subjective numeracy (e.g., Self-reported abilities and preferences for numbers, SNS; Fagerlin et al., 2007)
 - Approximate sense of numbers (From developmental literature)
2. Unintended consequences of shared decision making (e.g., increased patient responsibility may decrease willingness to accept risky treatments; Fraenkel & Peters, 2012)
3. Motivated cognition in medicine (e.g., vaccines, overdiagnosis/overtreatment?)
4. Longitudinal tracking of risk perceptions and comprehension of important health concerns

24



Thank you !

Current Challenges in the Psychology of Medical Decisions

Brian J. Zikmund-Fisher, PhD

University of Michigan

Department of Health Behavior & Health Education

Department of Internal Medicine

Center for Bioethics & Social Sciences in Medicine

Risk Science Center

5 Themes

- Information evaluability
- Narratives vs. facts
- Psychological underpinnings of overuse
- Mental models of risk
- Experiential learning

Information Evaluability

- Access to data \neq meaningful data
 - Less is more (Peters, Zikmund-Fisher)
 - Examples:
 - Risk calculators
 - Lab tests
 - Self monitoring devices
- Numbers vs. categories
 - E.g., Do DAs need numbers or gist tradeoffs?

Narratives vs. Facts

- Hard-wired for story
 - Elaboration of messages (Petty/Cacioppo)
 - Analytical vs. narrative persuasion
- Applications
 - Taxonomy of patient narratives (Shaffer)
 - Process vs. experience vs. outcome
 - Expressive writing as intervention (Rini)

Psychology of Overutilization

- Persistence of desire to act *despite statements of inefficacy or harm*
- Action bias
 - Cure me even if it kills me (Fagerlin)
 - Maximizing vs. Minimizing (Groopman / Hartzband ; Scherer)

Implications of Action Bias

- Disease label effects (Scherer)
- Failures to discontinue screening (Lewis / Saini)
- Overtreatment of low risk cancers
 - Prophylactic mastectomies?
- Many many more...

Mental Models of Health Risk

- Coronary stenting (Rothberg)
- Cancer genetics
 - Negative screen w/ family history
 - Whole genome sequencing
- Pregnancy weight gain
- IUDs

Experiential Learning

- Vaccine preventable diseases
 - No fear of what we never see
- Training skills vs. knowledge
 - Recognize the signs, titration, etc.
- Experiential methods of communicating risk
- Values clarification as intervention
 - Forcing people to experience tradeoffs

Health, Risk, and Decisions

Nidhi Agrawal

Foster
School of Business

UNIVERSITY OF
WASHINGTON

Overview

- Determinants of risk perceptions
- Emotional influences on decision-making
- Contextual influences
- Givers vs. recipients
- Health vs. Not Health reasons

Risk Perceptions

- Memory
 - What's on your mind right now → judgments and behavior
- Motivation
 - Unrealistic Optimism “Them. Not me”
- Feelings
 - Good and Bad side to uncertainty

Emotions

- Convey information
 - About the situation
 - About me
 - About others
- Set decision-making context

Contextual Influences

- Mindful behavior
- Mindless behavior
 - Habits

Giver vs. Recipient

- Psychological Distance
 - Distal – big picture, why, decontextualized
 - Proximal – details, how, contextualized
- Giver
 - Distal
- Recipient
 - Proximal

Health Vs. Non-Health Reasons

- Health and medicine → rational
 - Trade-offs
 - Reactance

- Fit, good-looking, easier, enjoyable → not all that rational

ETHICS & MEDICAL DECISION MAKING



@angie fagerlin

Angie Fagerlin, PhD / U of Michigan / VA Ann Arbor

Models Of Patient-Physician Decision Making

- 4 Models (Charles et al., 1997)
 - Paternalism
 - The informed decision making model
 - Professional as agent model
 - Shared decision making

- Mandatory autonomy

Role of Recommendations

- Physicians often asked “what would you do if it was your mom/dad”.
 - ▣ Physicians often provide recommendations even when not asked
- Recommendations have significant impact on treatment patients receive. (Ubel et al., In submission)
 - ▣ Patients’ preferences and values did not influence the prostate cancer treatment patients received.
- Recommendation primarily influenced by medical data (PSA/Gleason), not patients’ values/goals
 - ▣ Paternalism vs. Physician as Agent

Value vs. Fact

- Physicians often do not recognize when they are imparting facts vs. values (Ubel NEJM, in press)
 - Examples:
 - Active surveillance for Gleason 7 Prostate cancer
 - Boost radiation in breast cancer (recurrence risk vs. severe breast fibrosis)
 - So pass off values as fact (thus influencing recommendations)

How Much Information to Communicate

- People have difficulty determining the best decision when too much information is presented (Peters et al 2007; Zikmund-Fisher, Fagerlin, Ubel 2008; Fagerlin et al., 2012)
 - Especially problematic for individuals with lower numeracy skills
- How to choose which information to include (and exclude) or how to present complex risk/benefit information.
 - Layering of information
 - Classification of information (e.g., “severe side effects”)
- Gist vs. verbatim presentation

Use of Narratives

- 3 types: Process, experience, outcomes (Shaffer et al., 2012)
- Pros / cons
 - ▣ Not a key IPDAS criteria

Choice Architecture: An Overview

Eric J. Johnson
Columbia University

PCORI Medical-Decision Making Expert Meeting
June 4, 2015

Why *Beyond* Nudges

- Too often Choice Architecture has been taken to mean nudges
- Nudges seem to equal defaults or even mandates.
- Focuses on questions of intent and degree
 - When does a nudge become a shove?
 - Confuses ‘Libertarian Paternalism’ with the idea that choice architecture matters and is unavoidable.
- Clearly acknowledged in Nudge: “Cafeteria”
- But:

Nudge theory in practice

Politicians are wary of forcing us to do the things they think we should such as drinking less, saving more for our pensions or using public transport. But they are also reluctant to do nothing. The theories expounded in the book *Nudge*, published in 2008, suggested there was a third way: a "libertarian paternalist" option whereby governments made doing the right thing easier but not obligatory. Rather than making pensions compulsory, for example, governments could make saving for one the default option whilst preserving the right to opt out.

Nudge theory appealed to our better selves and to our politicians. The book's ideas were taken up by those inside government in Britain and the US.

One of the book's authors, Cass Sunstein, answers questions from an audience at the Institute for Government in London and tells presenter Edward Stourton how well he thinks his theories are working in practice.

Goals for Choice Architecture

Definition: Anything about how a option set is described and presented, usually of no normative consequence.

“Everyone is a choice architect”

- To make decisions easier.
- To make decisions more accurate reflections of their preferences.
- To help people construct preferences to make better hedonic forecasts.
- To make better tradeoffs between individual and societal goals.
- Improving consumers’ decisions will make markets more competitive *and* efficient.

Defaults Make a Difference

- Result: Defaults make a difference.
 - Examined Agreement rates in many European countries.
 - Most had web registrations.
- Econometric studies of actual rates show a 16-50% increase

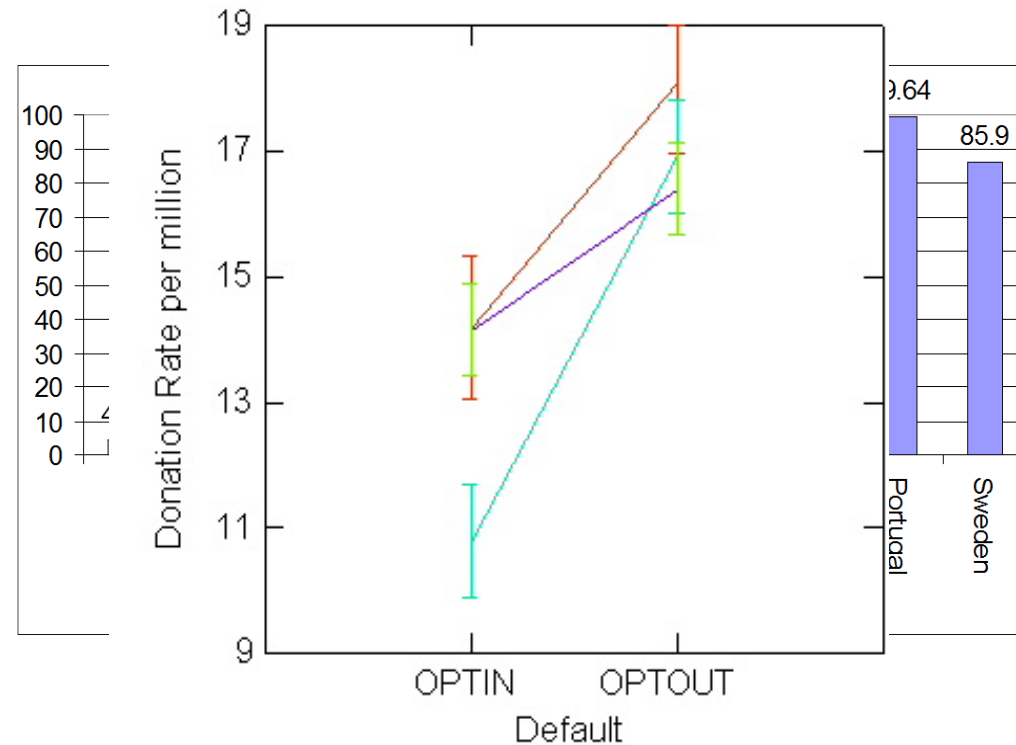

Classifying Mistakes: A Cost Benefit Story for Organ Donation.

	<i>Intended Categorization (no default)</i>	
Realized Categorization (opt in)	<i>Donor (79%)</i>	<i>Not Donor (21%)</i>
Donor (42%)	Correct classification; additional lives saved 33%	Incorrect classification, potential for indignation, negative publicity 8%
Not Donor (58%)	Incorrect classification; potential lives saved forgone. 45%	Correct classification 12%

More generally....

	Product A Fixed Rate Mortgage	Product B Variable Rate Mortgage
Should Choose Fixed Rate		
Should Choose Variable Rate		

Insurance Carrier	 CeltiCare	 Blue Cross Blue Shield of Massachusetts	 Fallon Community Health Plan
NCQA Rating	— N/A — Not yet rated - new insurer	★★★★★ 4 out of 4 stars View insurer's report card	★★★★★ 4 out of 4 stars View insurer's report card
Benefits Package	Silver Low Choose Plan	Silver Medium Choose Plan	Silver High Choose Plan

¹³The "Annual Deductible" is also referred to as the "deductible" in this grid. The deductible refers to the overall calendar year deductible, unless otherwise indicated. Some plans may have a separate deductible for specific benefits. For example, some plans may have a separate prescription drug deductible.

¹²The "Annual Out-of-Pocket Maximum" refers to the calendar year out-of-pocket maximum. In addition to the member costs for the nine services listed below, there may be other member costs that count towards the out-of-pocket maximum. Contact individual carriers if you have questions regarding the out-of-pocket maximum.

¹¹The "Annual Benefit Maximum" refers to the calendar year annual benefit maximum.

¹⁴Biologically based mental conditions include conditions that are listed in Chapter 176G of Massachusetts General Laws <http://www.mass.gov/legis/laws/mgl/176g-4m.htm>

The information presented above, including all quoted prices, is a summary for informational purposes only. Review the evidence of coverage, insurance policy, and any other health plan contract documents available from the insurance carrier for a detailed description of coverage benefits, limitations and exclusions. Only the terms and conditions of coverage benefits listed in the policy are binding.



Visit Mass.gov

Site Map · Feedback · Site Policies ·  

	Yes	Yes	Not applicable
Subject to annual deductible ¹	Yes	Yes	Not applicable
Separate DME deductible	None	None	None
¹⁴ DME	deductible, then \$0	\$0	30% co-insurance
¹⁴ DME limit	\$1,000 per calendar year	\$750 per calendar year	no limits

Recommended Preventive Services

Recommended preventive services	As a result of the Patient Protection and Affordable Care Act, plans will cover certain preventive services without any copays, deductibles, or co-insurance. Typically, this goes into effect on the start of a plan year that begins on or after September 23, 2010. For more details about which preventive services this includes, visit the federal government's website at: www.healthcare.gov	As a result of the Patient Protection and Affordable Care Act, plans will cover certain preventive services without any copays, deductibles, or co-insurance. Typically, this goes into effect on the start of a plan year that begins on or after September 23, 2010. For more details about which preventive services this includes, visit the federal government's website at: www.healthcare.gov	As a result of the Patient Protection and Affordable Care Act, plans will cover certain preventive services without any copays, deductibles, or co-insurance. Typically, this goes into effect on the start of a plan year that begins on or after September 23, 2010. For more details about which preventive services this includes, visit the federal government's website at: www.healthcare.gov
Recommended preventive services	As a result of the Patient Protection and Affordable Care Act, plans will cover certain preventive services without any copays, deductibles, or co-insurance. Typically, this goes into effect on the start of a plan year that begins on or after September 23, 2010. For more details about which preventive services this includes, visit the federal government's website at: www.healthcare.gov	As a result of the Patient Protection and Affordable Care Act, plans will cover certain preventive services without any copays, deductibles, or co-insurance. Typically, this goes into effect on the start of a plan year that begins on or after September 23, 2010. For more details about which preventive services this includes, visit the federal government's website at: www.healthcare.gov	As a result of the Patient Protection and Affordable Care Act, plans will cover certain preventive services without any copays, deductibles, or co-insurance. Typically, this goes into effect on the start of a plan year that begins on or after September 23, 2010. For more details about which preventive services this includes, visit the federal government's website at: www.healthcare.gov

Plan details	Download Plan Details	Download Plan Details	Download Plan Details

Select the most cost-effective plan for the next year, ignoring quality.

You go to the doctor 5 times, \$800 in Expense

Health Plan	Monthly Premium	Doctor Visit Copay	Annual Deductible	Expert Rating	Enrollee-Satisfaction
A	\$435	\$10	\$200	★★★★	★★★
B	\$376	\$28	\$735	★★★★	★★★
C	\$425	\$18	\$380	★★★	★★★★★
D	\$545	\$15	\$150	★★★★★	★★★
E	\$600	\$5	\$100	★★★	★★★★
F	\$369	\$40	\$850	★★★	★★★★★
G	\$417	\$10	\$550	★★★	★★★★
H	\$392	\$20	\$680	★★★★★	★★★

What Tools of Choice Architecture Are Useful?

- Limit the number of options
 - Standardize Plans.
 - Sort by some measure of quality
- Select Important Attributes
- Do necessary Math
- Pick 'Smart' Defaults
- Design Attributes to be easy to process.

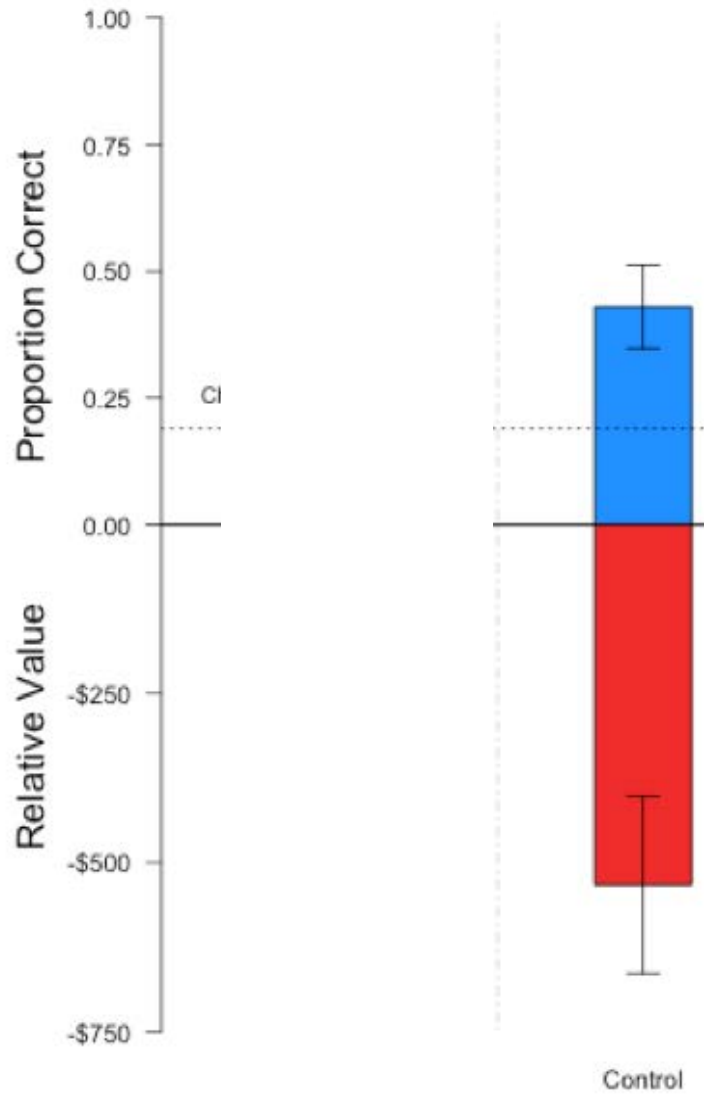

Ex. 6

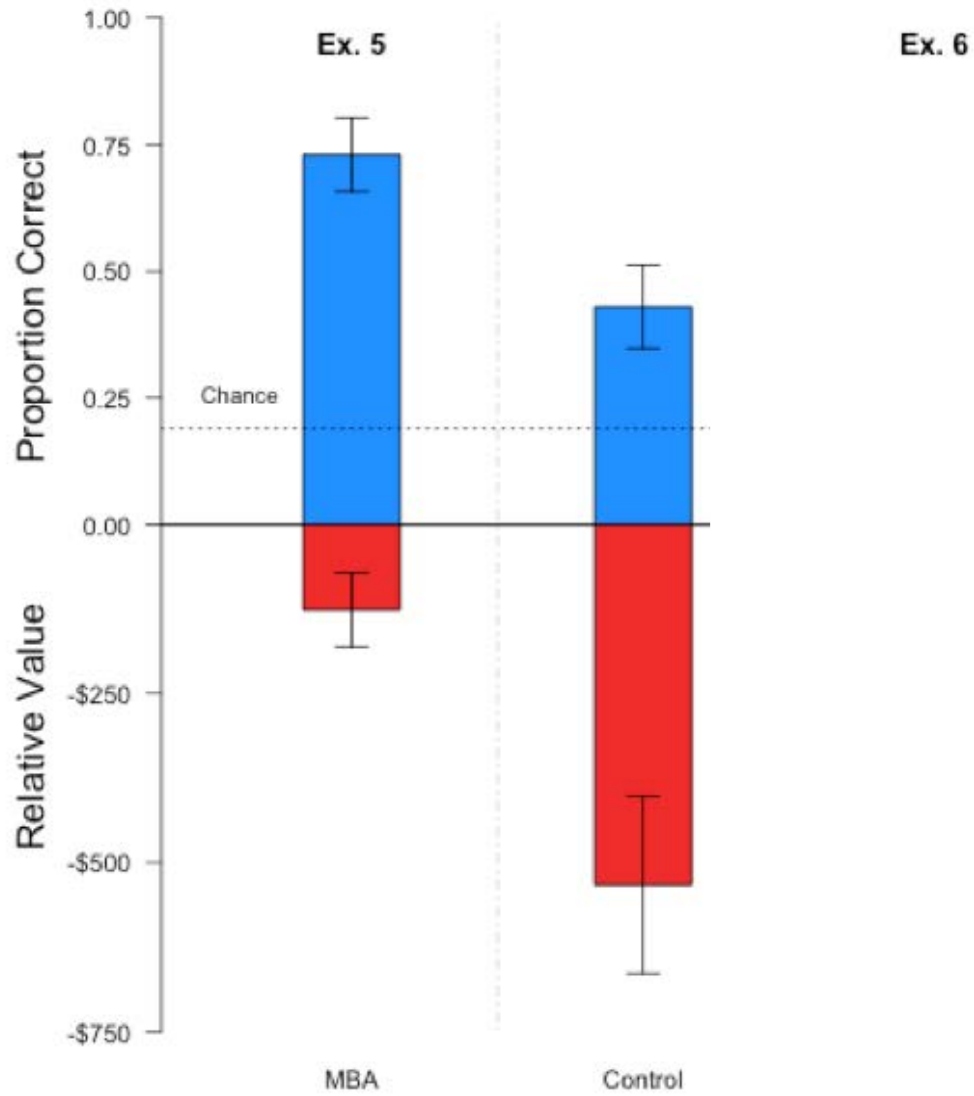

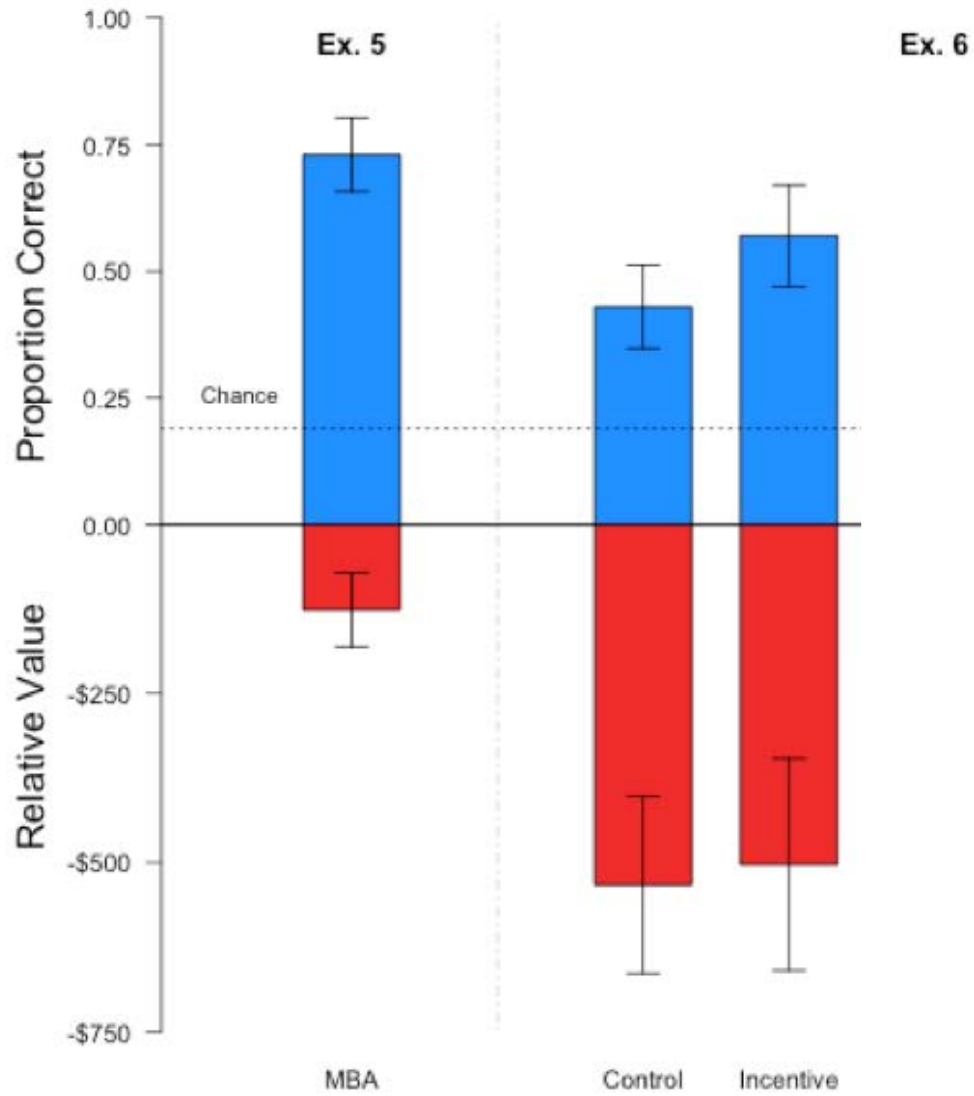

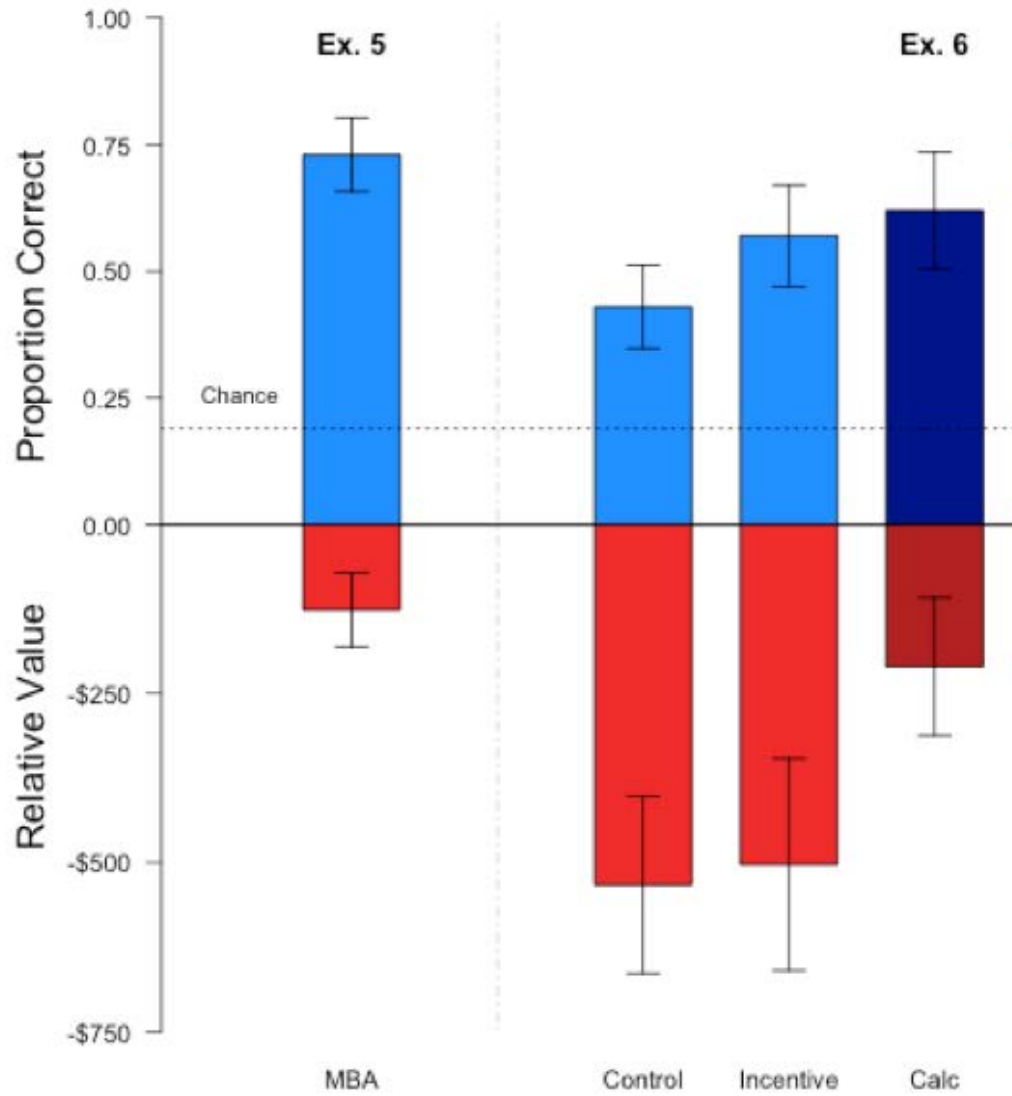

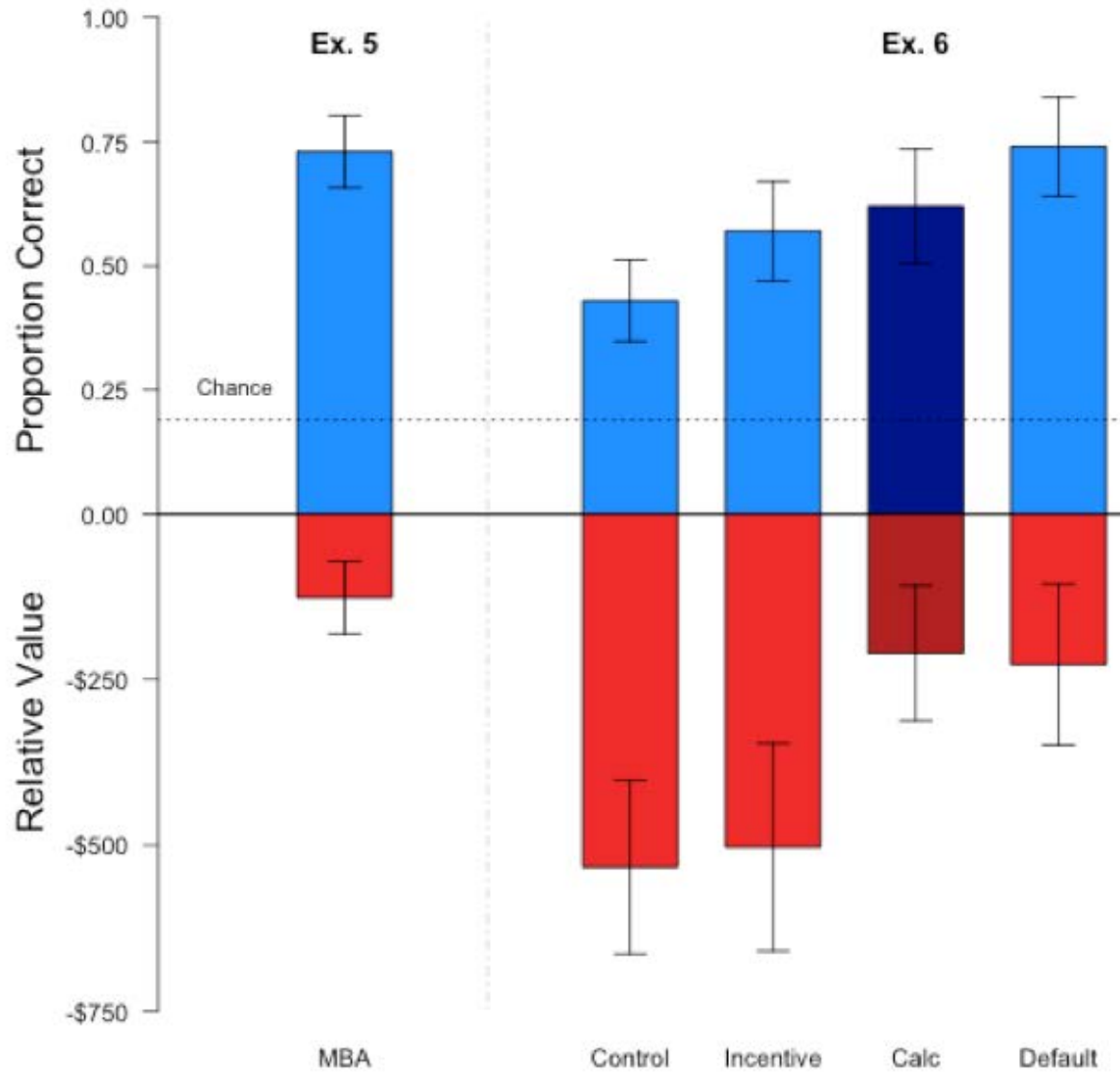

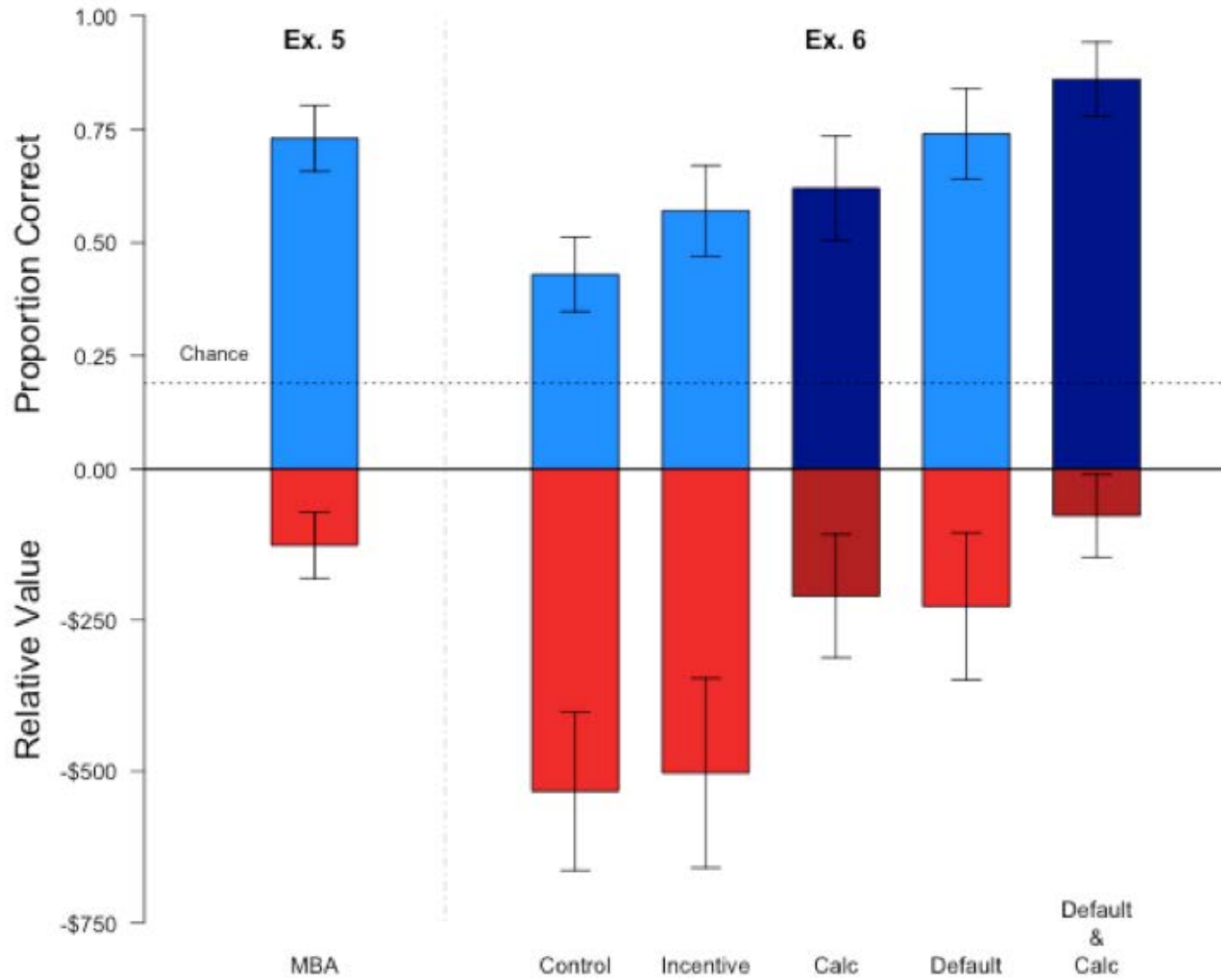

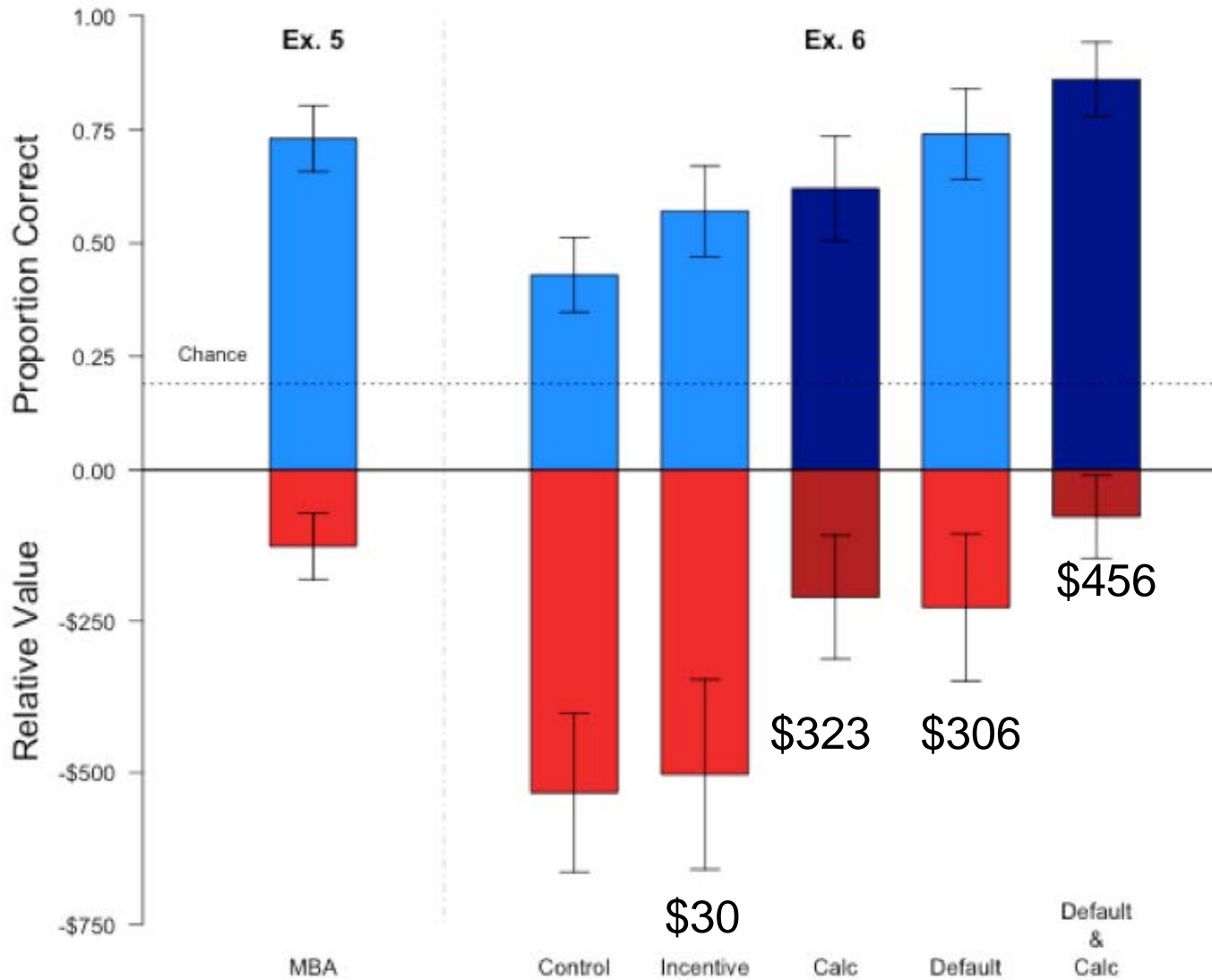

Outcomes

- Parts of our recommendations have, and will be implemented.

- The states are the laboratories of democracy:

“ a state may, if its citizens approve, serve as a laboratory; and try novel social and economic experiments without risk to the rest of the country”

- » Judge Louis Brandeis, *New State Ice Co. vs. Liebman*, 285 U.S. 262



Unsolved Problems..

- How aware are people of Choice Architecture interventions?
 - Initial results....Not very
- Can they predict the impact of CAIs?
 - They think they are not affected, but think others are affected....
 - They are not very accurate.
- How about disclosing choice architecture? What is its effect?
- Biggest questions:
 - What are the best CAI's, When?
 - How do CAI's work?

A Query Theory Checklist

"I don't want to have to work until I'm old—I

"Since people usually need more money to

"My family does not have a history of living

"My family has a history of living long, so I

"Instead of waiting until 70 years old to get the highest benefits, it is best to claim early

"I want to work as long as I physically can—only health problems would stop me from working."

Do you think this thought (or one very similar) will cross your mind while making the decision about when to begin claiming benefits?

Choose one of the following answers

- Yes
- No
- I don't know

Next >>

"I don't like my job anymore, so claiming benefits now would let me leave that bad situation."

Do you think this thought (or one very similar) will cross your mind while making the decision about when to begin claiming benefits?

Choose one of the following answers

- Yes
- No
- I don't know

Next >>

Effectiveness of Interventions

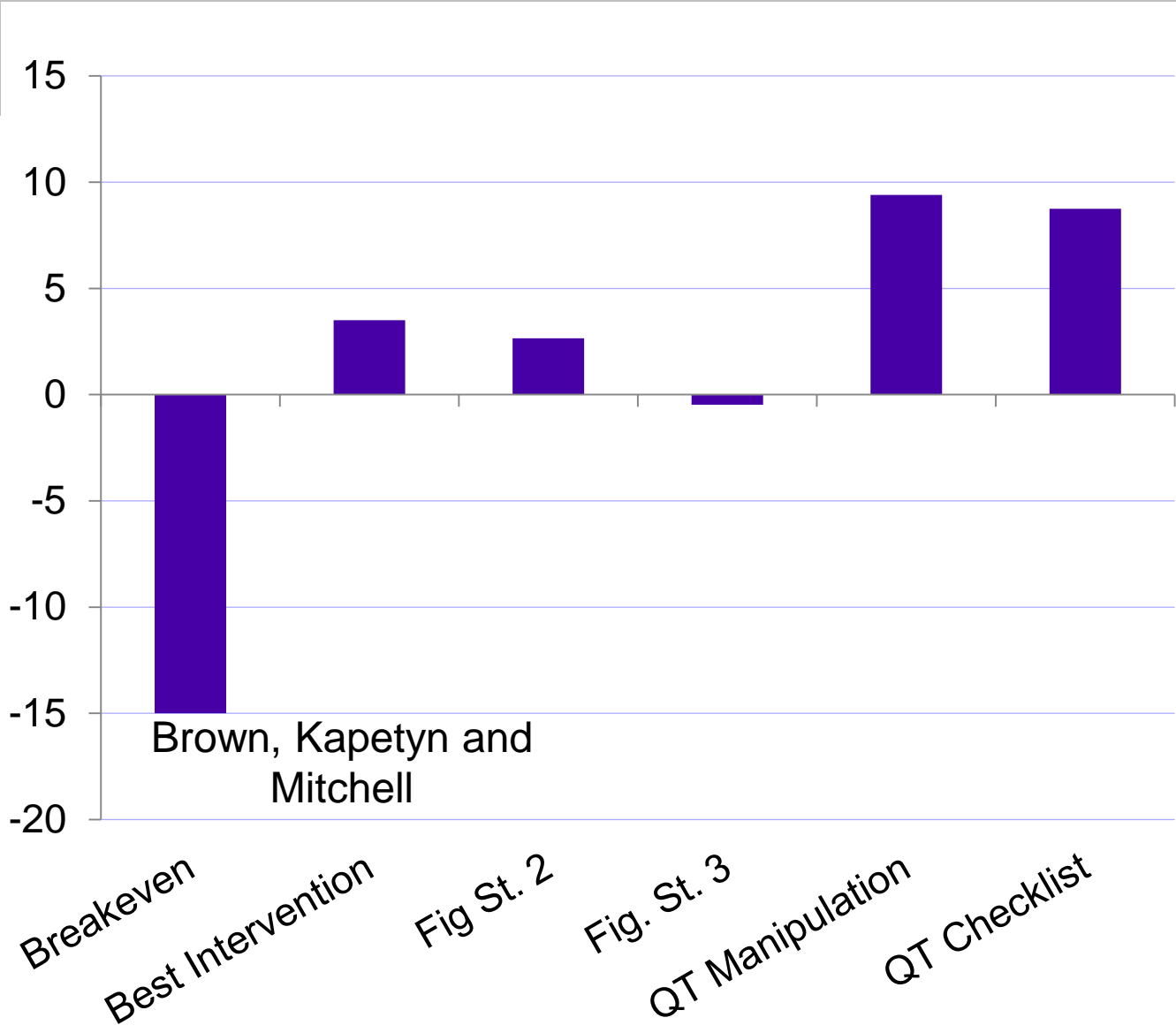

Behavioral economic approaches for improving end-of-life care

Scott D. Halpern, M.D., Ph.D.

Associate Professor of Medicine, Epidemiology, and Medical Ethics & Health Policy

Director, Fostering Improvement in End-of-Life Decision Science (FIELDS) program

Deputy Director, Center for Health Incentives and Behavioral Economics (CHIBE)



CENTER *for* HEALTH INCENTIVES *and* BEHAVIORAL ECONOMICS
at the LEONARD DAVIS INSTITUTE *of* HEALTH ECONOMICS

Grant support

NIH (NHLBI, NIA, NCI)

Robert Wood Johnson Foundation

American Heart Association

Greenwall Foundation

Otto Haas Charitable Trust

Gordon and Betty Moore Foundation

In-kind research support:

- Cerner
- CVS/Caremark
- Ascension Health

Motivations

- ✓ Most seriously ill patients prefer to avoid hospital-based care, yet 1 in 3 Americans die in a hospital (1 in 5 in an ICU)
- ✓ Last month of life: 1 in 2 patients visits an emergency room, 1 in 3 is admitted to an ICU, and 1 in 5 undergoes inpatient surgery
- ✓ 1 in 3 surrogates for patients dying in ICUs develops PTSD or depression
- ✓ 26% of Medicare costs for patients in last year of life



YOUNG LEADERS



The founder of Fostering Improvement in End-of-Life Decision Science (FIELDS), Scott Halpern, MD, PhD, MBE, discusses the issue of end-of-life care with colleagues at the Perelman School of Medicine at the University of Pennsylvania.

DOI: 10.1377/hlthaff.2012.1107

Employing Behavioral Economics And Decision Science In Crucial Choices At End Of Life

A program created by physician Scott Halpern employs multidisciplinary teams to help patients and family members make end-of-life decisions that track with their goals.

When Scott Halpern was a resident at the University of Pennsylvania, he was struck by the many failures in health care—and by how little the sector had drawn on lessons from other fields to correct them. Many patients “were not receiving known best practices”—such as having the heads of their beds elevated to reduce the risk of hospital-acquired infections, or having urinary catheters removed when they were no longer indicated.

Halpern knew that other fields had moved to reduce such human error through the use of checklists and other tools, or by making certain procedures automatic. He wondered why orders were not *automatically* placed for such processes of care, instead of requiring physicians to order the option that would best serve most patients.

These and other musings propelled Halpern to his current position as an assistant professor at the Perelman School of Medicine at the University of Pennsylvania—and to his status as a leader in the field of medicine, ethics, and decision science. An expert in behavioral economics, Halpern, 39, says he wants to use insights into the psychology of human decision making “to develop, test, and implement scalable interventions that improve the quality of the health decisions made by patients, family members, and providers.”

He has applied these approaches to choices about smoking cessation and organ donation. Now, he’s focusing on some of the most critical decisions humans can ever make: those connected with health care at the end of life.

To that end, Halpern formed the Fostering Improvement in End-of-Life Decision Science (FIELDS) program at Penn, which puts multidisciplinary teams to work improving the timing, content, and outcomes of the end-of-life decisions made by patients, family members, and providers. The program draws heavily on the behavioral economics concept of “choice architecture”—that is, the importance of the ways in which choices are presented and the environments in which decisions are made. Halpern and his colleagues believe that it’s possible to shape these influences on choice so that patients’ and family members’ decisions are more likely to match their own real goals.

Ezekiel Emanuel, Penn’s vice provost for global initiatives and chair of the Department of Medical Ethics and Health Policy, sums up Halpern’s work: “The key tension [he] explores is that as a society, we wish to support the authority and autonomy of patients.... How-

Advance directives



The 'failure curve' of AD implementation

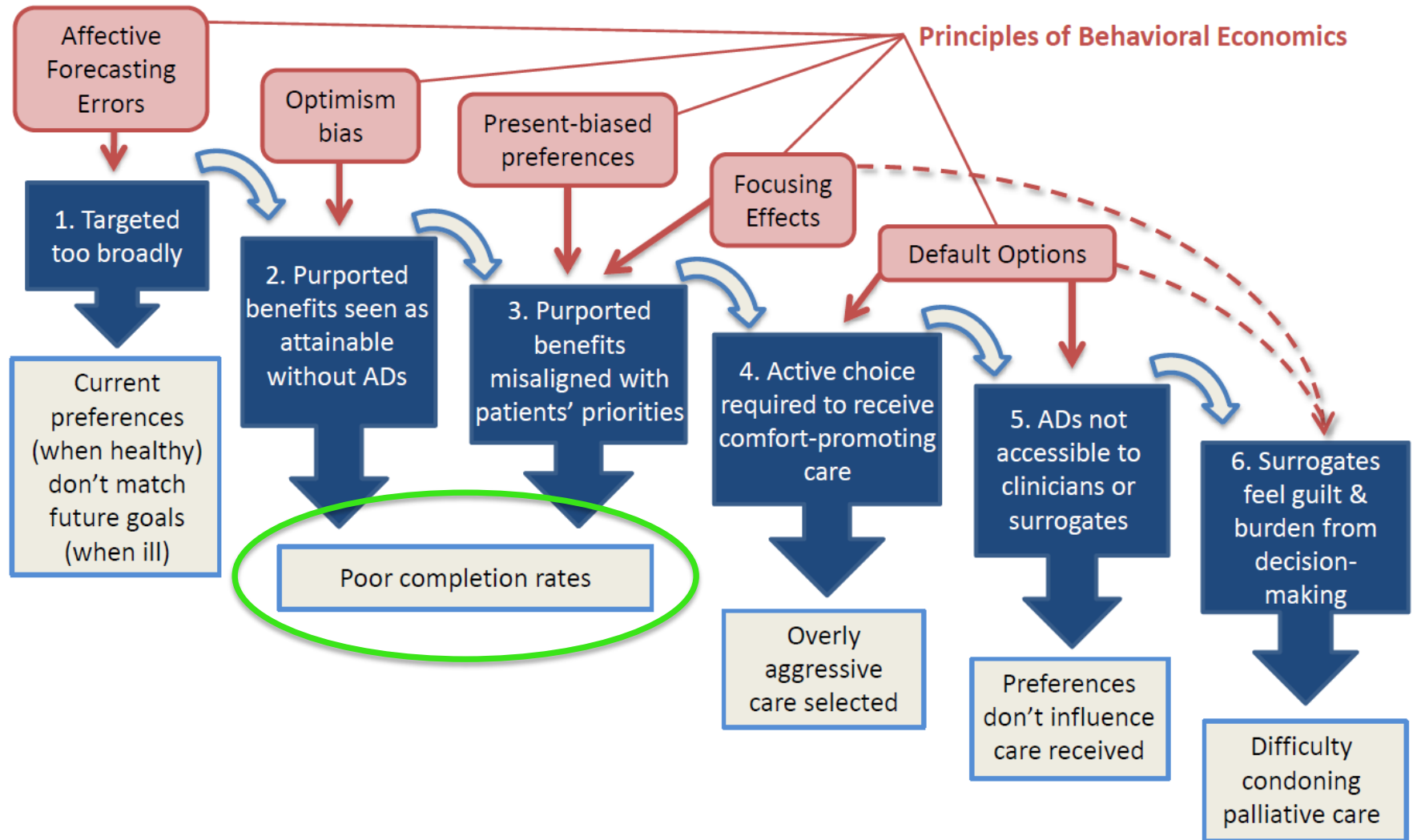

“Forcing” active choice promotes choice

Prescription Drug Home Delivery

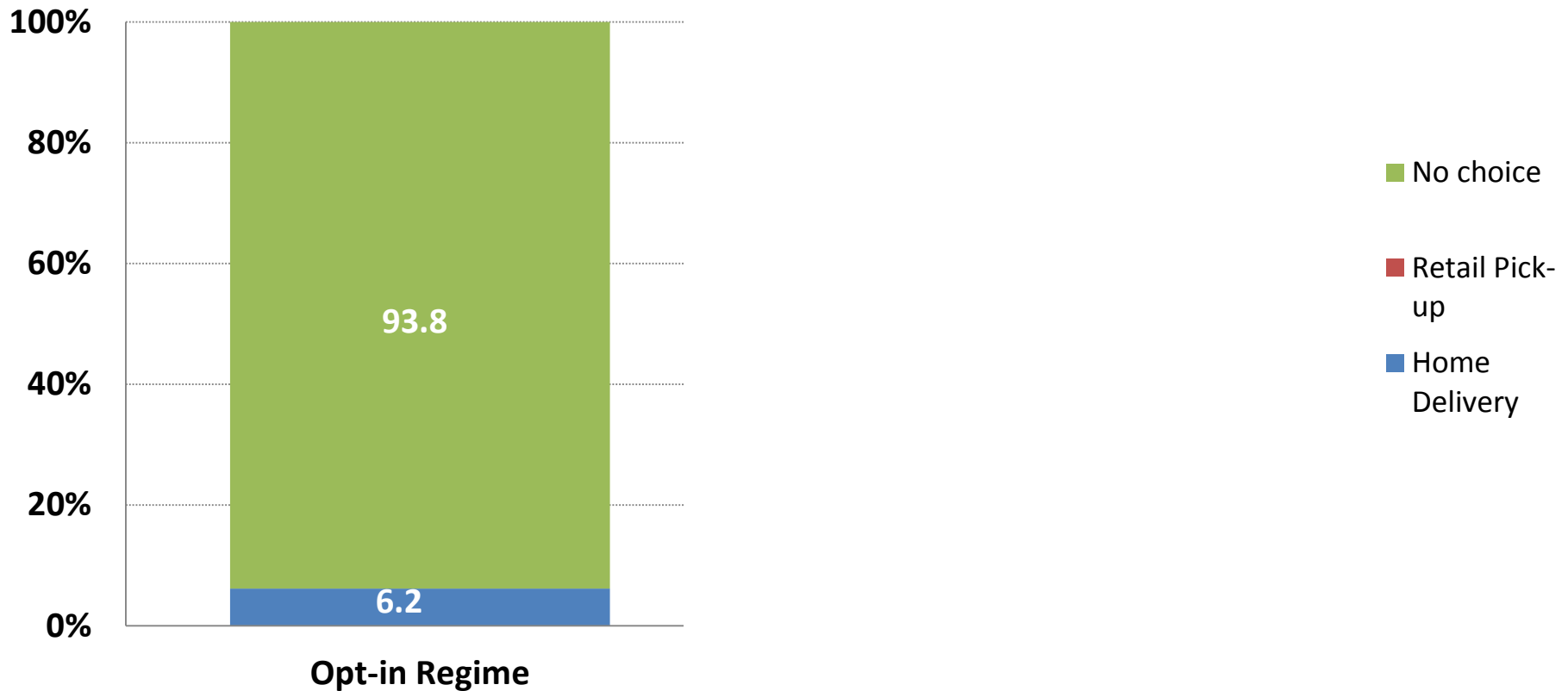

INTERVENTION



911
employees
randomized
to date



CONTROL

Future Healthcare Planning

This task is **REQUIRED** for completion of the On Boarding process.

Please choose any one of the selections below to complete the Healthcare Planning task.

An advance health care directive is also called a living will. If you become seriously ill and cannot make decisions for yourself, an advance directive tells your doctors and family how you want to be treated and who you want to make health care decisions for you.

For further information you can refer to our online brochure at [Advance Directive Brochure.pdf](#), or you can call one of our specialists at 215-898-0861 during business hours.

Complete an Advance
Directive
39%

Decline opportunity to
complete an Advance
Directive

Confirm that I have an
Advance Directive

Future Healthcare Planning

This task is **OPTIONAL** for completion of the On Boarding process.

Please choose one of the selections below, or skip this and return to the On Boarding portal.

An advance health care directive is also called a living will. If you become seriously ill and cannot make decisions for yourself, an advance directive tells your doctors and family how you want to be treated and who you want to make health care decisions for you.

For further information you can refer to our online brochure at [Advance Directive Brochure.pdf](#), or you can call one of our specialists at 215-898-0861 during business hours.

Complete an Advance
Directive
21%

Confirm that I have an
Advance Directive

[SKIP>>](#)

Effects of expanding choice sets

	<i>Share (%)</i>
<i>Category: microwave oven</i>	<i>Set 1</i> <i>(n = 60)</i>
<i>x Emerson</i> <i>(.5 cu. ft.; regular \$109.99; sale price 35% off)</i>	
<i>y Panasonic I</i> <i>(.8 cu. ft.; regular \$179.99; sale price 35% off)</i>	

Expanding choices for ESRD patients

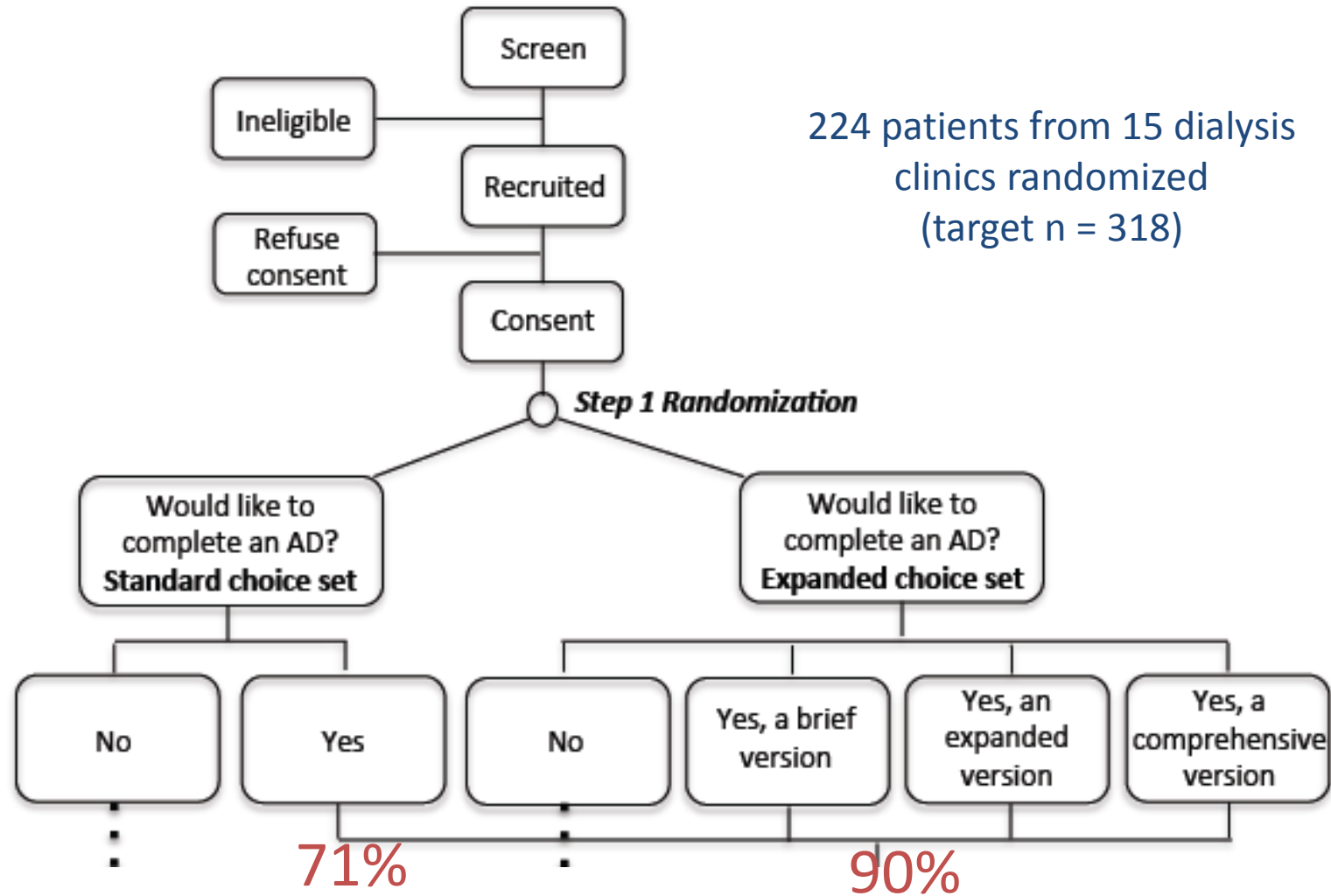

The 'failure curve' of AD implementation

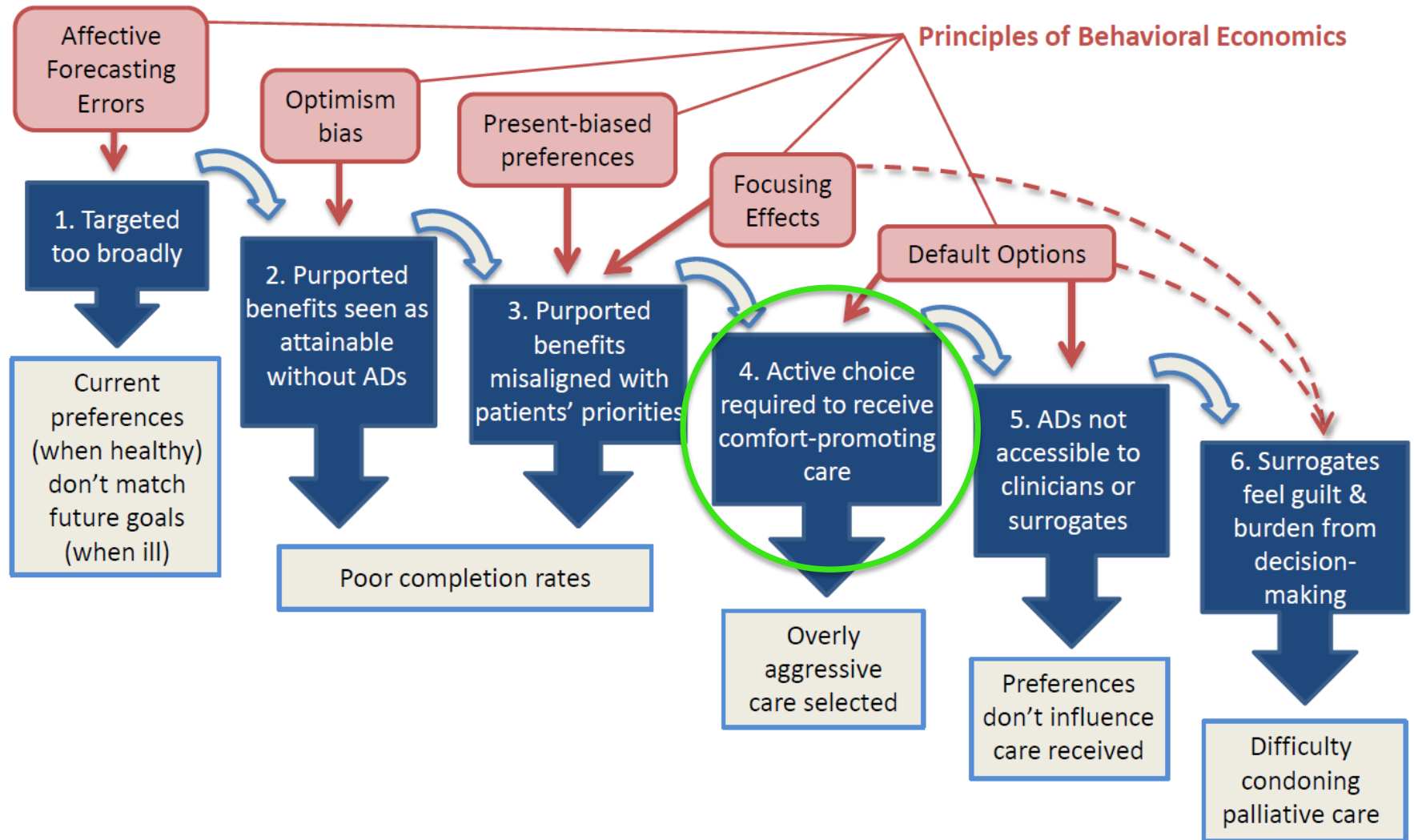

Standard advance directive

Overall Goals of Care

_____ I want my healthcare providers and agent to treat me by helping relieve my pain and suffering, even if that means that I may not live as long.

OR

_____ I want my healthcare providers and agent to treat me by helping me to live as long as possible, even if that means that I may have more pain or suffering.

OR

_____ I do not want to specify one of the above goals. My healthcare providers and agent may direct the overall goals of my care.

In addition, I want my healthcare providers and agent to focus on the following goals (optional):

Default = Surrogate + Physician must decide

Comfort default

Overall Goals of Care

I want my healthcare providers and agent to treat me by helping relieve my pain and suffering, even if that means that I may not live as long.

*If you prefer to choose a different overall goal of care, **cross out** the lines above and place your initials by one of the other options below:*

I want my healthcare providers and agent to treat me by helping me to live as long as possible, even if that means that I may have more pain or suffering.

OR

I do not want to specify one of the above goals. My healthcare providers and agent may direct the overall goals of my care.

In addition, I want my healthcare providers and agent to focus on the following goals (optional):

RCT of default options in real ADs

- 132 patients with advanced emphysema, lung cancer, and other terminal diseases recruited from Penn outpatient clinics
- Most who refused consent didn't want to complete an AD
- After debriefing, no patients changed their care choices

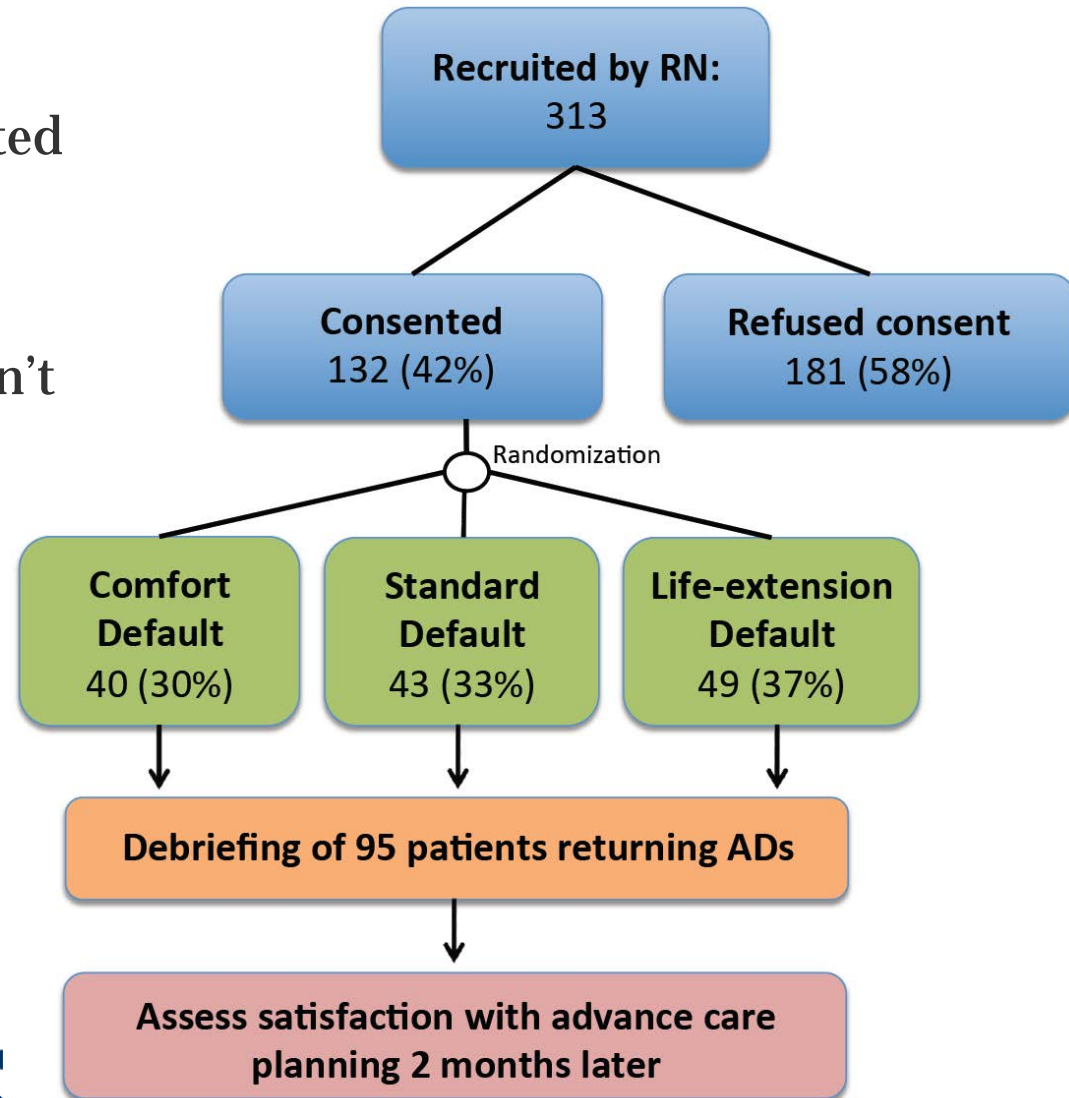
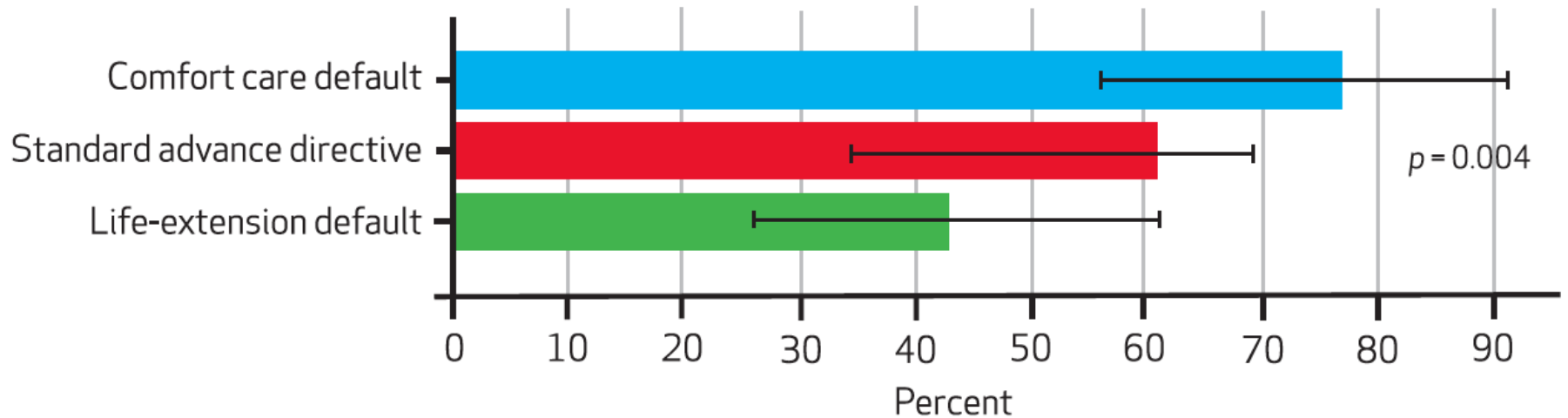

EXHIBIT 2

Percentage Of Patients Choosing A Comfort-Oriented Goal Of Care (Per Protocol Population)



Default Options in Advance Directives

Study Protocol

February 19, 2014

A prospective randomized controlled trial to examine whether structuring advance directives to request comfort-oriented goals of care by default improves patients' quality of life and reduces resource utilization without reducing the number of days that patients are alive and living outside of an acute-care hospital.

Supported by:

The Gordon and Betty Moore Foundation

NCT 0201754

Outcomes= days alive and living outside of an acute-care facility; stability of preferences; patient QOL; surrogate bereavement

Study schema

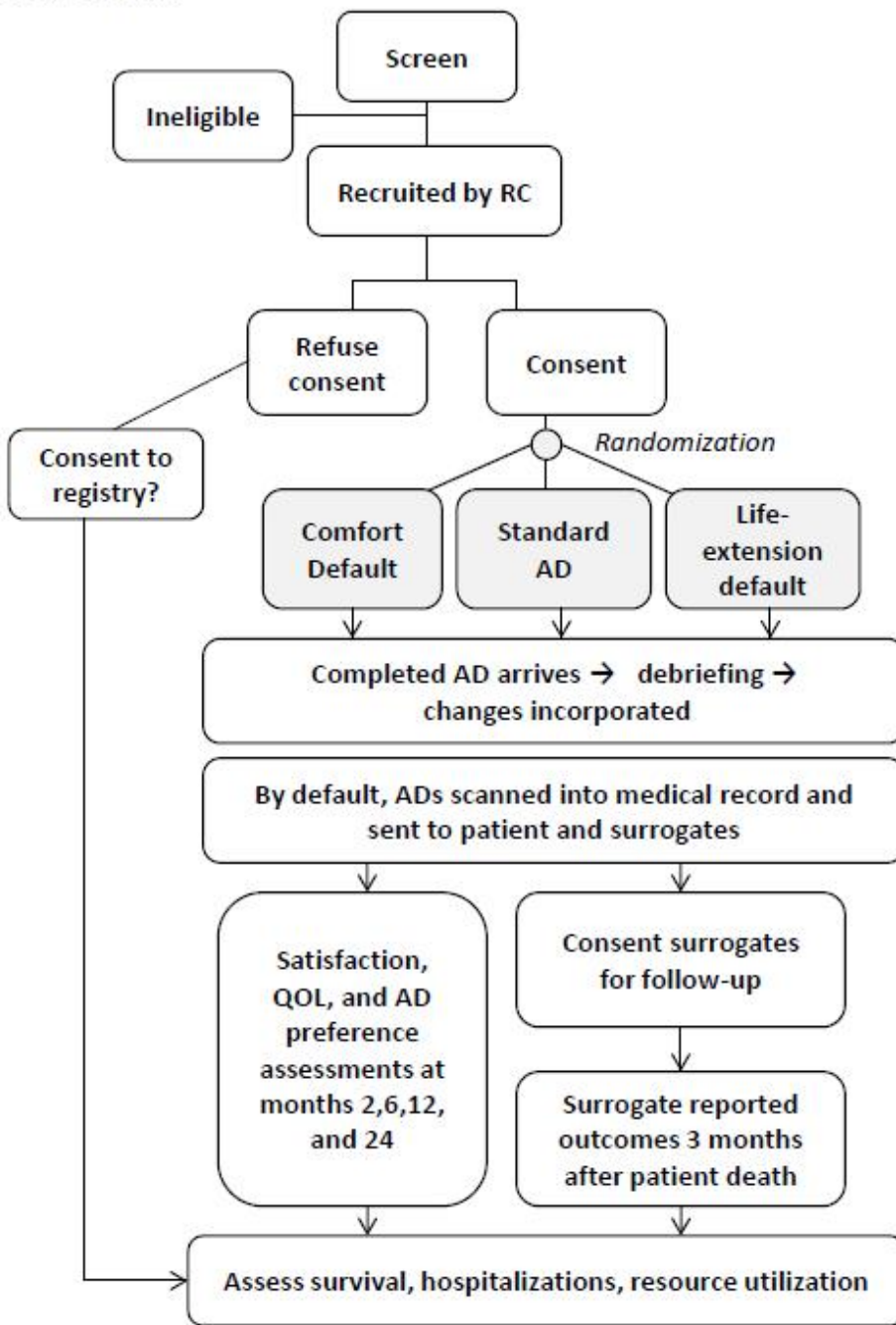

Improving inpatient palliative care



Inpatient palliative care: Not enough of a good thing?

- 85% hospitals >50 beds have inpatient pall care services (IPCS)
- Observational evidence suggests improved outcomes, lower costs
- In non-cancer populations, <10% of 'targeted' patients seen

Figure 1. Conceptual Model of Influences on the Effectiveness and Costs of Inpatient Palliative Care Services (IPCS)

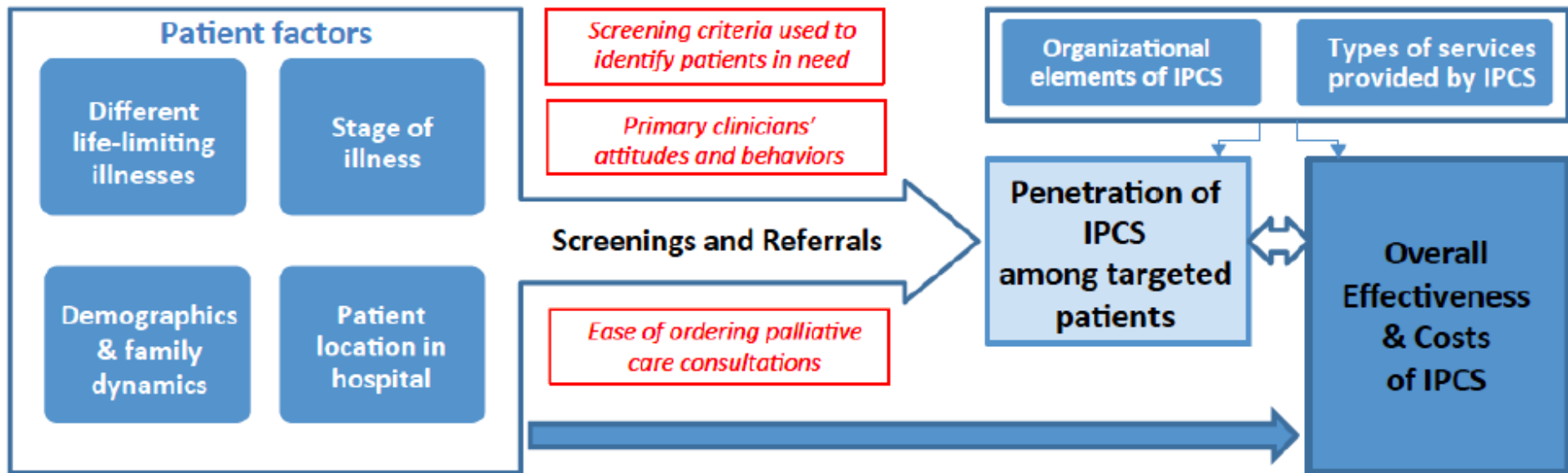

REDAPS: Randomized Evaluation of Default Access to Palliative Services

Table 2. Eligibility criteria

<i>Life-limiting illness</i>	<i>Additional criteria required</i>
End-stage renal disease (ESRD)	<ul style="list-style-type: none"> • None
Chronic obstructive pulmonary disease (COPD)	<ul style="list-style-type: none"> • Home oxygen dependence; or • 2 or more additional hospitalizations within 12 months
Dementia (all types)	<ul style="list-style-type: none"> • Admitted from a long-term-care facility (e.g., nursing home); or • Prior placement of surgical feeding tube (e.g., PEG); or • 2 or more additional hospitalizations within 12 months

Primary outcome: composite of hospital LOS and mortality

Secondary outcomes: documentation of goals of care, family meetings, and pain assessments; readmissions; costs; other

Comparison: usual care (palliative care consultation at MD discretion) vs. default EHR-ordered palliative care consultation on 3rd hospital day

Sample: ~20,000 patients at 11 Ascension Health hospitals with integrated EHR

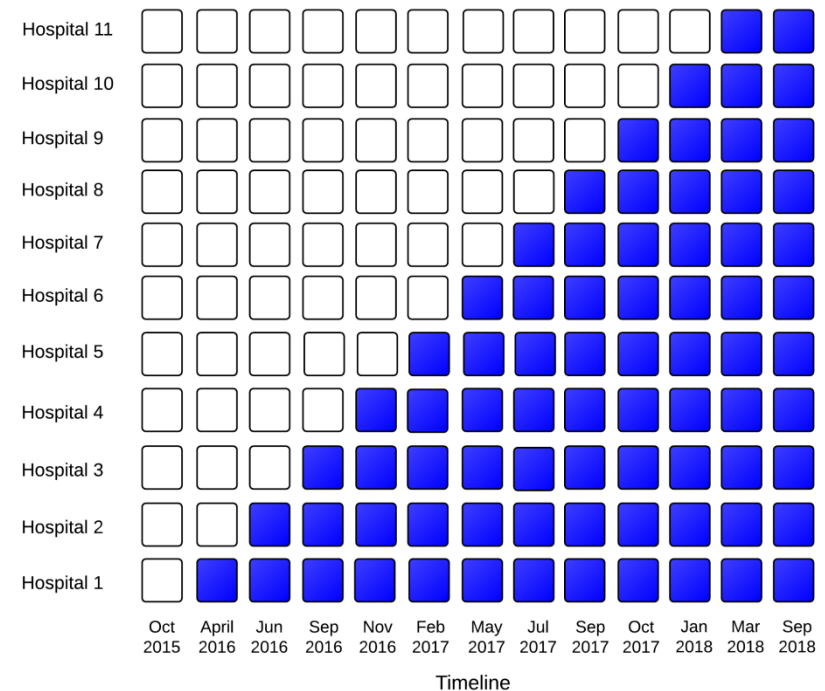

Shaded cells represent intervention periods; blank cells represent control



Conclusions

- Many seriously ill patients lack deep-seated preferences regarding the healthcare they want near the end of life
 - Clinicians, health systems, and policy makers need to do more than than “promote discussions” and “elicit preferences”
- Behavioral economic insights suggest low-cost & scalable ways to:
 - Build better advance directives & motivate patients to complete them
 - Engage physicians in offering palliative approaches to care
 - Circumvent physicians’ reluctance to prognosticate & recommend

Acknowledgements

PENN FIELDS team

Dominique Bayard, MD
David Casarett, MD
Elizabeth Cooney, MPH
Kate Courtright, MD
Michael Detsky, MD
Mary Ersek, RN, PhD
Sarah Grundy
Michael Joseph
Nicole Gabler, PhD
Michael Harhay, PhD (c)
Joanna Hart, MD, MS
Emma Levine, PhD (c)
Vanessa Madden, BSc
Mary McKenzie, MD, MS
Mark Mikkelsen, MD, MS
Michael Olorunnisola
Emily Rubin, MD, JD
Sarah Ratcliffe, PhD
Dylan Small, PhD
Stephanie Szymanski
Kevin Volpp, MD, PhD

Carnegie Mellon

George Loewenstein, PhD

University of Pittsburgh

Derek Angus, MD, MPH
Bob Arnold, MD
Cindy Bryce, PhD
Doug White, MD, MAS



chibe.upenn.edu/fields-program

shalpern@exchange.upenn.edu

Choice Architecture

Jennifer Blumenthal-Barby, PhD

PCORI Expert Meeting:
Advancing Medical Decision Making

Baylor
College of
Medicine

CENTER FOR
MEDICAL ETHICS
& HEALTH POLICY

With this in mind, we set out nine of the most robust (non-coercive) influences on our behaviour, captured in a simple mnemonic – MINDSPACE – which can be used as a quick checklist when making policy.

Messenger	we are heavily influenced by who communicates information
Incentives	our responses to incentives are shaped by predictable mental shortcuts such as strongly avoiding losses
Norms	we are strongly influenced by what others do
Defaults	we 'go with the flow' of pre-set options
Salience	our attention is drawn to what is novel and seems relevant to us
Priming	our acts are often influenced by sub-conscious cues
Affect	our emotional associations can powerfully shape our actions
Commitments	we seek to be consistent with our public promises, and reciprocate acts
Ego	we act in ways that make us feel better about ourselves

This table comes from: *MINDSPACE: Influencing Behavior Through Public Policy*; U.K. Institute for Government, 2010.

[1 Unanswered Ethical Question]

- Often people say that C.A. cannot be avoided.
“A choice architect has the responsibility for organizing the context in which people make decisions. Many real people turn out to be choice architects, most without realizing it. If you are a doctor and must describe the alternative treatments available to a patient, you are a choice architect. There is no such thing as a neutral design.” – Thaler & Sunstein, *Nudge*, p. 3
- To some extent this is true.
- But some of the tools on the previous slide are not things one *has* to use in constructing or engaging people (patients, docs) in H.C. decision-making.
- Is there an ethically relevant difference between using C.A. tools one cannot avoid (e.g., setting a default) and “extras” (e.g., norms info) and how to think of grey areas (e.g., is priming unavoidable C.A. or extra)?

- Each of these tools has (and can be) been applied to various areas of health care decision-making to help people make better decisions.
- One goal of this meeting may be to look at some of these examples and generate new ideas (and think about the ethics of those).

Application of C.A. tools in H.C.

Existing applications

- Defaults: organ donation, screening/testing (HIV, sickle cell, cancer), advance care planning (non life sustaining treatment, DNR status), generic prescriptions (docs).
- Incentives (esp. lottery, give and then subtract): walk/exercise, lose weight, take medications, stop smoking, get vaccinated (rural India), pick up HIV test results (Malawi), take birth control/avoid pregnancy (teens), improve your patients' risk factors (docs).
- Salience and Affect: videos for vaccination, DNR/non-LST in advanced dementia, cigarette package labeling, patients' faces on x-rays (docs).
- Norms: info about others'/peers' habits/choices (not smoking, wearing sunscreen, exercising, taking medications...active surveillance for low-risk prostate cancer?).
- Messenger: doc recommendation (cancer screening), peer messenger.
- Priming: subconscious cues such as reducing food container sizes, framing options (e.g., risks first, frequencies instead of percentages).
- Commitments and Ego: contract/written intent for exercise.

General Ethical Considerations & Unanswered Questions

- Ends: How do we determine them/what are they (theoretically and concretely)? Especially in cases where there is no “clear” answer (contrast exercising more with selecting medical management over surgery).
 - Hedonic Utility: aim to increase good feelings/happiness.
 - Preferences: aim to increase satisfaction of what people say they want.
 - Informed Preferences: aim to increase satisfaction of what people want once fully informed.
 - Objective List: aim to increase satisfaction of some list of goods such as health or longevity. Who makes list/how? Involve pt. stakeholders but still...
 - Individually tailored (e.g., person A prefers longevity) vs. population (e.g., everyone else prefers QOL)? Including existing C.A. context considerations (heavily biased towards surgery, end may be consider active surveillance), which may be dynamic/change over time.
 - Even the act of eliciting preferences involves C.A.

General Ethical Considerations & Unanswered Questions

Baylor
College of
Medicine

CENTER FOR
MEDICAL ETHICS
& HEALTH POLICY

- Means: Must avoid interference with autonomy and damaging trust.
 - C.A. (a form of “non-argumentative influence”) is *not* necessarily incompatible with autonomy. We generally consider ourselves to be self-governing or autonomous despite the fact that our states of mind and actions are constantly influenced by the external world, the past, and non-rational means.
 - Key questions are:
 - Are options significantly blocked or burdened? It needs to be **fairly easy for a person to go a different way**.
 - What is or would the person’s attitude be towards the fact that she is being influenced by mechanism X in context Y (would she repudiate or **endorse that process by which her decision was formed?**)
 - Even if autonomy is not being *interfered with* is there an obligation to *promote* it by encouraging the person to consider options in light of her preferences, values, and goals and is the instance of C.A. interfering with that?
 - Would patient perceive it as an instance of dishonesty, disrespect, patronizing, etc. which would damage **trust**?

Specific Ethical Considerations

Blumenthal-Barby & Burroughs, Am J Bioethics, 2012

Baylor
College of
Medicine

CENTER FOR
MEDICAL ETHICS
& HEALTH POLICY

Table 1. Summary of recommendations

Nudge mechanism	Ethically relevant considerations
Incentives	<ul style="list-style-type: none"> ● The amount and kind of incentives used. ● Whether the incentive plan will disadvantage those most in need or result in the group that fails to meet criteria for receipt being treated unfairly (e.g., cost-shifting to those who fail, leaving those who fail by the wayside). ● Whether the incentive plan will harm the patient–physician relationship (e.g., through actual or perceived monitoring). ● Whether the incentive is fairly directed (e.g., at patients as opposed to or in addition to their physicians if the patients themselves are the ones who improved their health).
Defaults	<ul style="list-style-type: none"> ● Whether people are aware of the existence of the default and whether it is fairly easy for people to opt out. ● Whether the expected benefits of the default outweigh any anticipated harms, where harm is construed not just physically but also psychologically, socially, and financially. ● Whether there are injustices or harms brought about to vulnerable or marginalized populations by the default (e.g., presumed consent for organ donation exploits the homeless who do not have easy opportunities to opt out/dissent) and whether attempts have been made to mitigate those effects.
Salience and affect	<ul style="list-style-type: none"> ● Whether what is being represented saliently is true and accurate, as opposed to exaggerated or misrepresented. ● Whether the use of salience and affect techniques will be perceived negatively by those it is directed toward. ● Whether bypassing people’s capacity for reason is done for good ends (e.g., not selfish ones) and for good reasons (e.g., people are harming themselves). ● Whether there is a justification for using salience and affect instead of rational argument.
Norms and messenger	<ul style="list-style-type: none"> ● Whether the information about what “most people are doing” is true and accurate. ● Whether the use of comparisons and norms will do more good than harm in light of the fact that “what most people do” is often unwise. ● Whether the power differentials between messenger and recipient have been considered.
Subconscious priming	<ul style="list-style-type: none"> ● Whether it is fairly easy for people to go in a direction other than the one in which they are primed. ● Whether subconscious priming is done for good and evidence-based ends. ● Whether there is a justification for using subconscious priming instead of rational argument.
Commitments and ego preservation	<ul style="list-style-type: none"> ● Whether ego is used for good ends and good reasons and whether there is a justification for using ego instead of rational argument. ● Whether the person is making a commitment to self-destructive ends. ● Whether the commitment is to long-term preferences or fleeting ones.

Concluding Remarks

- Other areas of interest for application of C.A.: vaccination; selection of insurance plans; decision aid design; low-value care; prostate cancer decision-making; end of life. Areas where clear answer (evidence and patient preferences point one way and goal of C.A. is to increase uptake) vs. areas where less clear but C.A. considerations should not be ignored/pretended to be absent.
- Gaps: patients' perspective on these matters (means and end; and in specific cases). Complexity in eliciting and C.A.
- Ethical analysis will be context/case specific, even though I have outlined some general considerations (compare: messenger (doc) to recommend vaccination vs. to recommend against tracheostomy in case of child with devastating neurological injuries; to recommend to an upper class educated parent vs. a less powerful one).

Baylor
College of
Medicine®

CENTER FOR
MEDICAL ETHICS
& HEALTH POLICY